

TSTE19

POWER ELECTRONICS

EXAMINATION (TEN1)

SOLUTIONS

Time: Wednesday 14 January 2015 at 8.00 - 12.00

Place: U4, U6

Responsible teacher: Martin Nielsen-Lönn, ISY, 070-361 52 44 (martin.nielsen.lonn@liu.se)
Will visit exam location at 8:45 and 10.

Number of tasks: 6

Number of pages: 9

Allowed aids: Calculator

Total points: 70

Notes: A pass on the exam requires approximately 30 points.
Remember to indicate the steps taken when solving problems.

Exam presentation: Friday 30 January 2015 12:45-13:30 (Filtret, B-building)

Instructions

Write as detailed as you can and describe what you are doing. It is better to write if you are unsure about some step or equation instead of just using it.

Questions

Question 1

- (a) In short terms, describe what kind of filter you need for a PWM controlled inverter. (2)

Solution:

Since using a high switching frequency a LP-filter with a high cutoff-frequency can be used.

- (b) Why do you want electrical isolation in a power supply? (2)

Solution:

For example: safety requirements, different ground levels is required etc.

- (c) Why is high frequency switching preferred in modern power converters? (2)

Solution:

When using a high switching frequency the filters used to remove the harmonics can have a higher frequency and therefore smaller components. Also the efficiency can be improved due to smaller losses.

- (d) What values can the displacement power factor (DPF) have? *Hint: How is it defined?* (2)

Solution:

DPF is defined as cosine of the phase difference between the voltage and current. So its range is,

$$DPF = \cos(\phi) = [0 : 1].$$

- (e) What component (resistor, capacitor, inductor) can, in the right circumstances, be modeled as an ideal current source? (2)

Solution:

An inductor since it, if large enough, will have an almost constant current running through it.

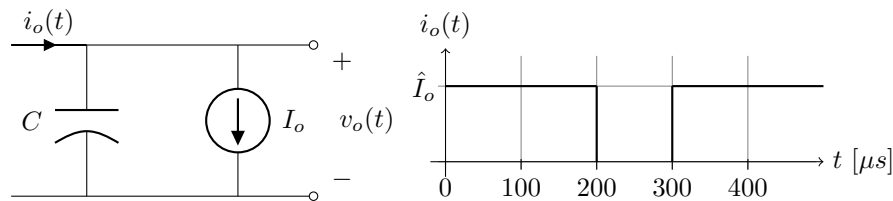

Figure 1: Circuit and waveform for question 2

Question 2

Consider the circuit and current graph in figure 1. The average output voltage, V_o , is 5 V, the peak output current, \hat{I}_o , is 3 A, C is $1000 \mu\text{F}$ and the switching frequency, f_s , is $\approx 3.33 \text{ kHz}$.

- (a) What is the average output current, I_o ? (3)

Solution:

$$I_o = \hat{I}_o D = \frac{\hat{I}_o t_{on}}{T} = 3 A \frac{200 \mu s}{300 \mu s} = 2 A$$

(b) Draw the voltage waveform of $v_o(t)$.

(6)

Solution:

$$i_c(t) = i_o(t) - I_o$$

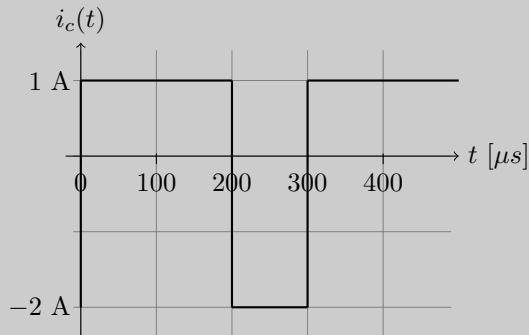
 i_c alternates between 1 A and -2 A.

The capacitor across the capacitor is equal to the output voltage,

$$i_c(t) = C \frac{dv_c(t)}{dt} = C \frac{dv_o(t)}{dt}.$$

Integrating both sides,

$$\Delta v_o = \frac{1}{C} \int_{t_0}^{t_{on}} 1 A dt = \frac{1}{1000 \mu F} \int_0^{200 \mu s} 1 A dt = \frac{1}{1000 \mu F} [t]_0^{200 \mu s} = \frac{200 \mu A s}{1000 \mu F} = 200 mV$$

Since the average output voltage is 5 V and the output current is a square wave the waveform for the output voltage is piecewise linear with 200 mV peak-to-peak around 5 V,

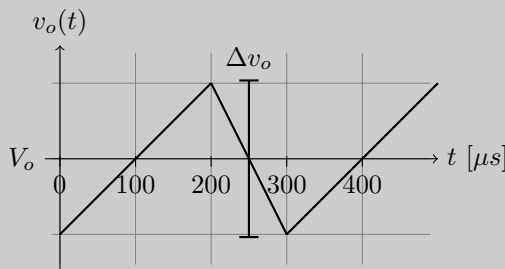
**Question 3**Consider the circuit in figure 2 with the following values: $V_d = 12$ V, $L = 37.5 \mu H$, $D = 0.25$, $I_o = 1.5$ A and $f_s = 100$ kHz. Assume that C is large and that it works in continuous conduction mode.(a) What kind of circuit is this and what is the ratio between the output and input voltages? *Hint: Is $V_{out} > V_{in}$, vice versa or is the ratio arbitrary?* (2)**Solution:**

Step-down converter

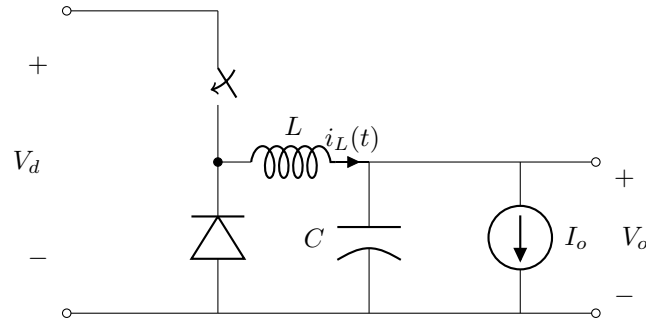

Figure 2: Circuit for question 3

- (b) Mention two other types of DC-DC converters and what their ratio between the output and input voltage are? *Hint: See part 1.* (4)

Solution:

For example: Step-up(boost) which has a higher output voltage than input voltage and buck-boost which can have both a higher or lower output voltage than the input voltage.

- (c) What is the output voltage? (2)

Solution:

$$V_o = V_d D = 12 \times 0.25 = 3 \text{ V}$$

- (d) Sketch the waveforms for $v_L(t)$ and $i_L(t)$. Indicate the times, average values, all voltages and the peak-to-peak current. (4)

Solution:

Beginning by calculating the average i_L as,

$$I_L = I_o = 1.5 \text{ A}$$

and drawing a sketch of them,

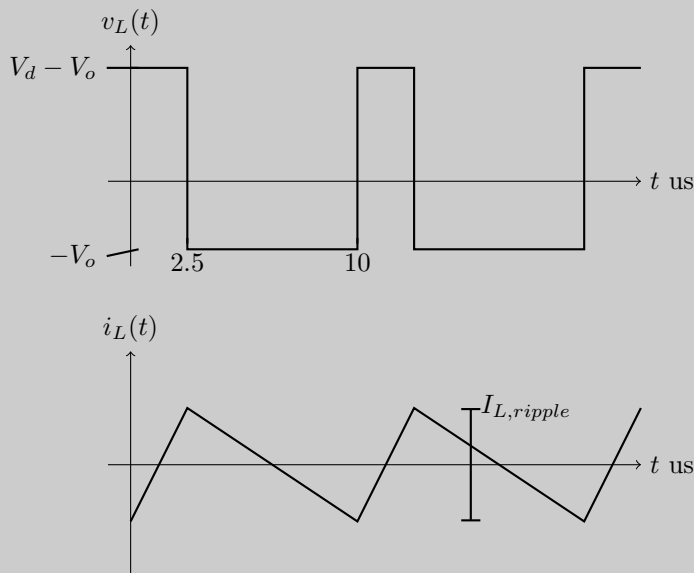

Note that the baseline in the current waveform is equal to I_o .

The ripple in the current, $I_{L,ripple}$, can be calculated by integrating the voltage over the inductor from time 0 to DT_s ,

$$I_{L,ripple} = \frac{1}{L_s} \int_0^{DT_s} v_L(t) dt = \frac{DT_s(V_o - V_d)}{L_s} = \frac{0.25(12 \text{ V} - 3 \text{ V})}{37.5 \mu\text{H} \times 100 \text{ kHz}} = 0.6 \text{ A}.$$

- (e) Calculate the minimum switching frequency to keep continuous conduction mode. (6)

Solution:

If the converters operate at the boundary between continuous and discontinuous mode the inductor current, i_L , will touch 0 at the end of each period. This gives that the average output current will equal half of the peak inductor current.

$$\hat{I}_L = 2I_o = 2 \times 1.5 \text{ A} = 3 \text{ A}.$$

When the switch is closed the voltage across the inductance, v_L , is,

$$v_L = V_d - V_o = 12 \text{ V} - 3 \text{ V} = 9 \text{ V}.$$

The current change during this time is,

$$\hat{I}_L = \frac{T_s D v_L}{L}$$

Rearranging and solving for $f_s = 1/T_s$ gives,

$$f_s = \frac{D v_L}{\hat{I}_L L} = \frac{0.25 \times 9 \text{ V}}{3 \text{ A} \times 37.5 \mu\text{H}} = 20000 \text{ Hz} = 20 \text{ kHz}.$$

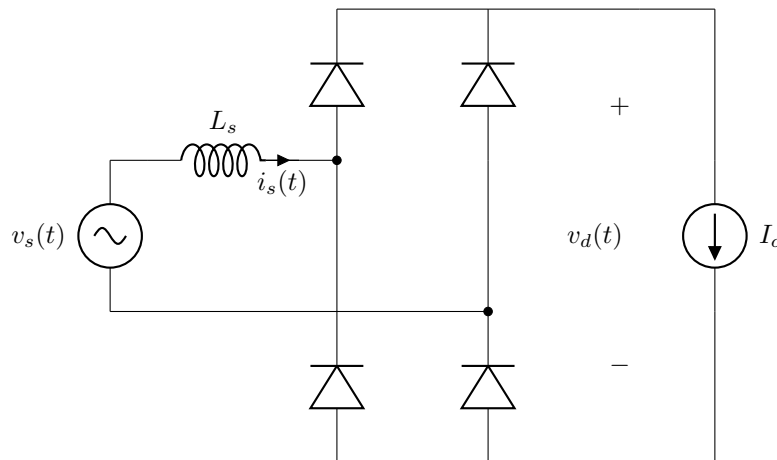
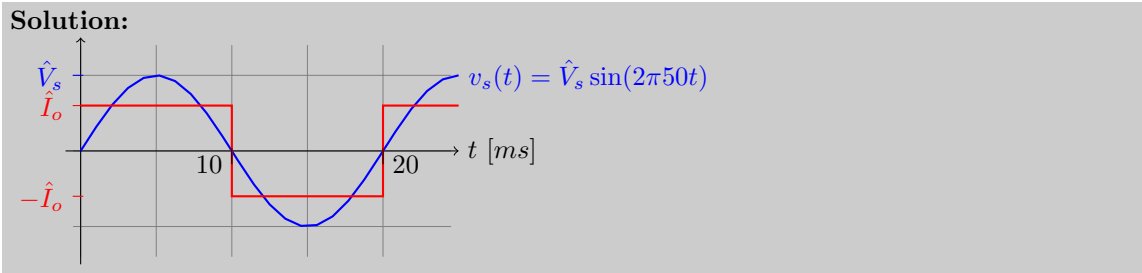

Figure 3: Circuit for question 4

Question 4

The rectifier in figure 3 have a load current I_o of 2 A. Assume that all the diodes are ideal.

- (a) Draw the waveforms of $v_s(t)$ and $i_s(t)$ if L_s would be zero and v_s is a sinusoidal voltage with 240 V_{RMS} at 50 Hz, and describe which diodes are conducting at each interval and why. (2)



- (b) Calculate the 3 first harmonics of i_s , that is the fundamental and the two following harmonics, and present them in table with frequency and amplitude. Assume L_s is still zero. (3)

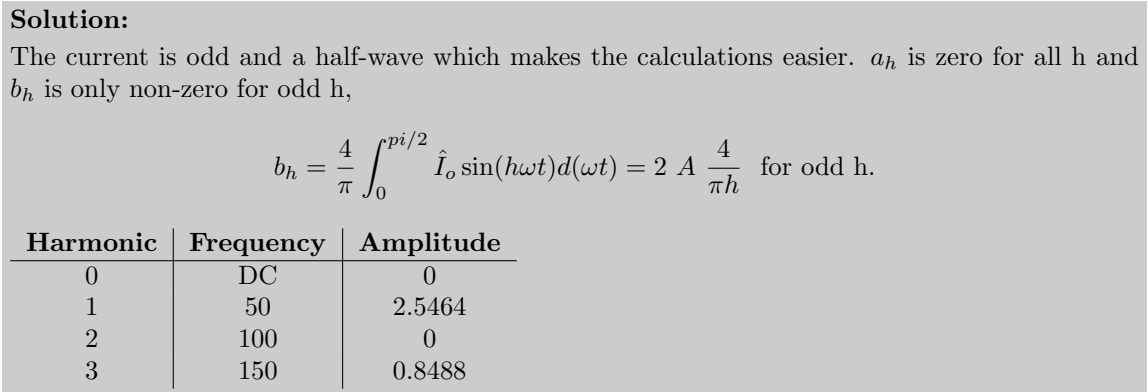

- (c) Draw the waveforms of $v_s(t)$ and $i_s(t)$ if L_s is 200 mH and v_s is a square wave with 300 V amplitude at 50 Hz, and describe which diodes are conducting at each interval and why. (3)

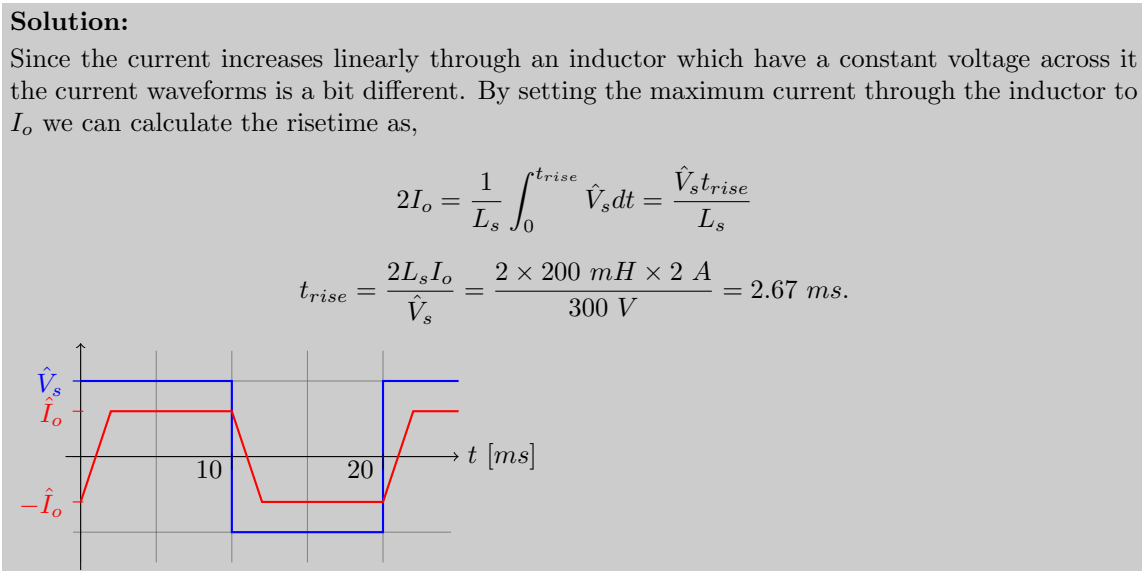

Question 5

A smartphone has a Li-Ion battery with 3.7 V between the poles and the SoC (System-on-chip) is running at 1.2 V and dissipates an average of 5 W. Since the Li-Ion battery drops in voltage over time a switching DC-DC converter is used to regulate the voltage which has an efficiency of 95%. Of course the smartphone should work in warmer countries than Sweden and the specification mentions that the

ambient temperature can be expected to peak at 40°C. Your job is to design a heat sink for the DC-DC converter.

- (a) What is the maximum power dissipated by the DC-DC converter? (3)

Solution:

Since the efficiency is 95% the dissipated power is,

$$P_{\text{diss}} = 5 \text{ W} \times \left(\frac{1}{0.95} - 1 \right) = 5 \text{ W} \times 0.05263 = 0.263 \text{ W} = 263 \text{ mW}.$$

- (b) Draw the thermal equivalent circuit and calculate the required Θ_{ca} for the heat sink assuming that Θ_j is 1°C/W and that the maximum case temperature is 60°C. (5)

Solution:

The thermal equivalent circuit is,

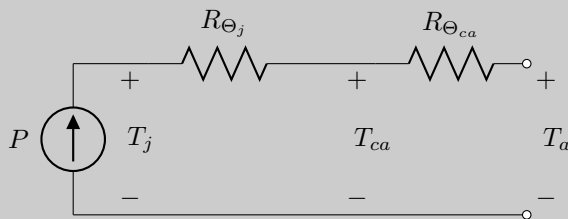

Where P is the power dissipated in the circuit and T_a the ambient temperature. Seeing that we do not care about the junction temperature the circuit boils down to,

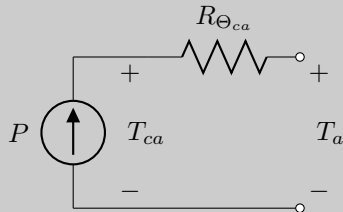

Which gives the following equation,

$$R_{\Theta_{ca}} = \frac{T_c - T_a}{P} = \frac{60^\circ\text{C} - 40^\circ\text{C}}{0.263 \text{ W}} = \frac{20^\circ\text{C}}{0.263 \text{ W}} = 76^\circ\text{C/W}$$

Question 6

The thyristor based inverter showed in figure 4 have the input voltage v_s shown to the right in the same figure. All thyristor have a 30° firing angle. The current source load I_o is 3 A and the inductor L is 100 mH.

- (a) Draw the output voltage v_o and the source current i_s , indicating which thyristor is on (conducting) and off (not conducting). (6)

Solution:

The firing angle is 30° which is equal to 1.67 ms ($20 \text{ ms} \times 30/360$). Assume thyristors T_2 and T_3 are on, and v_s is changing from negative to positive. Then the current $i_s = -I_o$. When v_s goes positive, the current still continuous to run through T_2 and T_3 (thyristors do not turn off unless the current is zero). When T_1 and T_4 are fired, then all thyristors will conduct. The voltage v_o goes to 0, and the voltage across L is now equal to v_s and i_s changes. When i_s has reached I_o

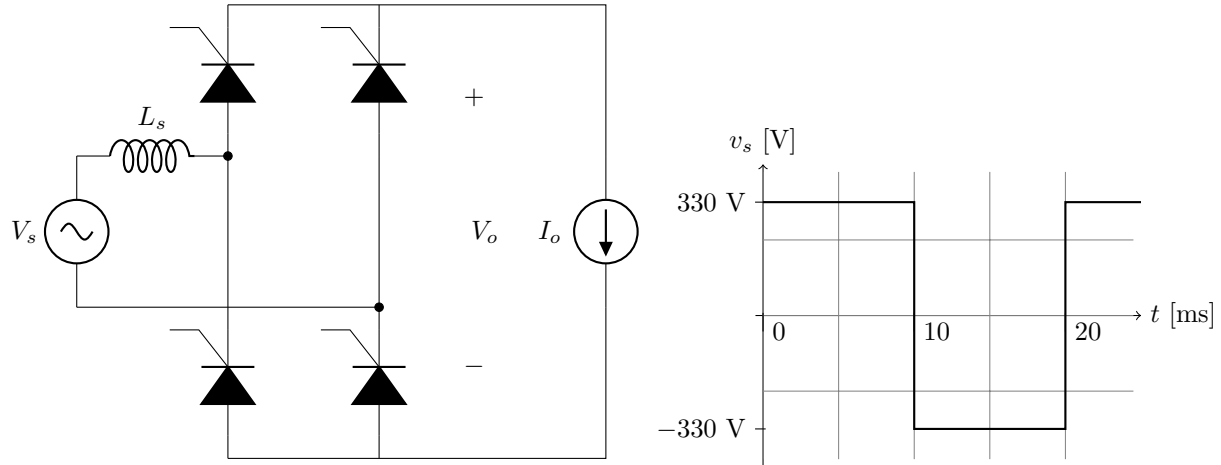
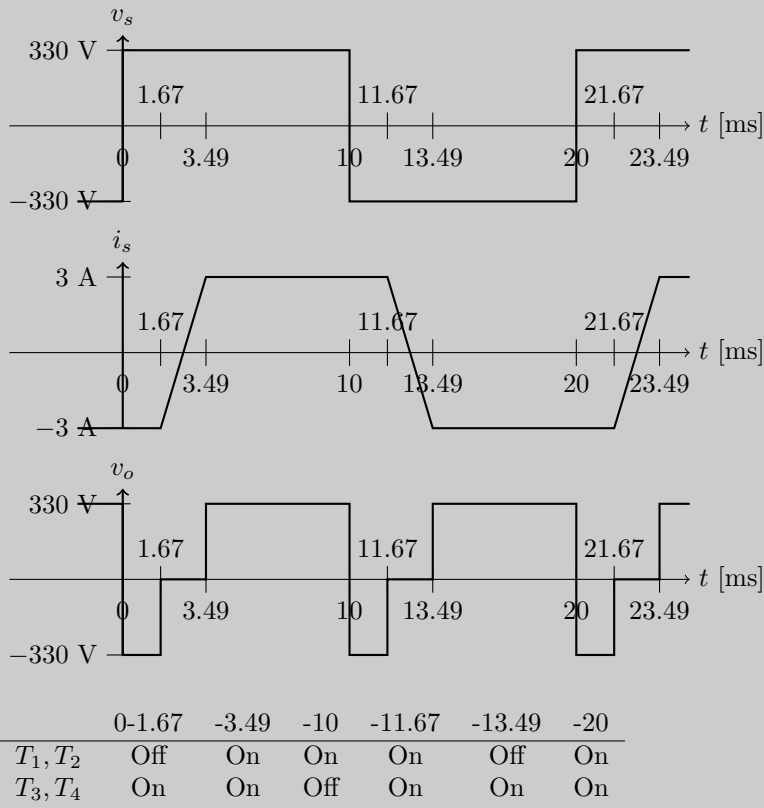

Figure 4: Circuit and waveform for question 6

then T_2 and T_3 turns off. The time to change current direction through L (total change is $2I_o$) is,

$$t_{sw} = \frac{2I_o L}{v_s} = \frac{2 \times 3 \text{ A} \times 100 \text{ mH}}{330 \text{ V}} = 1.818 \text{ ms.}$$

The waveforms thus look like,



(b) Calculate the average output voltage.

(6)

Solution:

$$V_{o(avg)} = \frac{1}{T} \int_0^{10} v_o(t) dt = \frac{1}{10} (330(10 - 3.49) - 330 \times 1.67) = \frac{330}{10} (10 - 3.49 - 1.67) \approx 160 \text{ V}$$

(c) Calculate the displacement power factor (DPF) for the input power.

(5)

Solution:

Displacement angle is found by looking at the middle point of high output current,

$$\frac{11.67 \text{ ms} - 3.49 \text{ ms}}{2} + 3.49 \text{ ms} = 7.58 \text{ ms}.$$

The voltage peak middle point is $10 \text{ ms}/2 = 5 \text{ ms}$. This gives us the current displacement angle,

$$\phi = \phi_v - \phi_i = \frac{7.67 \text{ ms} - 5 \text{ ms}}{10 \text{ ms}} 180^\circ = 46.44^\circ.$$

Putting this angle into the formula for DPF gives,

$$DPF = \cos(\phi) = \cos(46.44^\circ) = 0.69$$

Formula collection TSTE19 Power Electronics

Fourier series coefficients using symmetri, Table 3.1

Even	$f(-t) = f(t)$	$b_h = 0$	$a_h = \frac{2}{\pi} \int_0^\pi f(t) \cos(h\omega t) d(\omega t)$
Odd	$f(-t) = -f(t)$	$a_h = 0$	$b_h = \frac{2}{\pi} \int_0^\pi f(t) \sin(h\omega t) d(\omega t)$
Half-wave	$f(t) = -f(t + \frac{1}{2}T)$	$a_h = b_h = 0$ for even h	
		$a_h = \frac{2}{\pi} \int_0^\pi f(t) \cos(h\omega t) d(\omega t)$ for odd h	
		$b_h = \frac{2}{\pi} \int_0^\pi f(t) \sin(h\omega t) d(\omega t)$ for odd h	
Even quart-wave	Even and half-wave	$b_h = 0$ for all h	
		$a_h = \frac{4}{\pi} \int_0^{\frac{\pi}{2}} f(t) \cos(h\omega t) d(\omega t)$ for odd h, $a_h = 0$ for even h	
Odd quarter-wave	Odd and half-wave	$a_h = 0$ for all h	
		$b_h = \frac{4}{\pi} \int_0^{\frac{\pi}{2}} f(t) \sin(h\omega t) d(\omega t)$ for odd h, $b_h = 0$ for even h	

Undamped resonant circuits

Undamped series resonant circuit, equation 9-3, 9-4

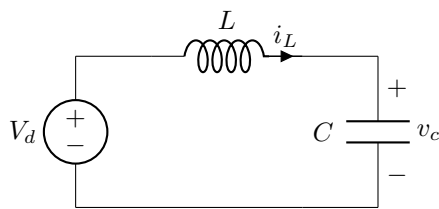

$$i_L(t) = I_{L0} \cos(\omega_0(t - t_0)) + \frac{V_d - V_{c0}}{Z_0} \sin(\omega(t - t_0))$$

$$v_c(t) = V_d - (V_d - V_{c0}) \cos(\omega(t - t_0)) + Z_0 I_{L0} \sin(\omega_0(t - t_0))$$

Undamped parallel resonant circuit, equation 9-20, 9-21

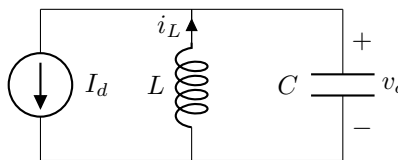

$$i_L(t) = I_{L0} \cos(\omega_0(t - t_0)) + \frac{V_d - V_{c0}}{Z_0} \sin(\omega(t - t_0))$$

$$v_c(t) = V_d - (V_d - V_{c0}) \cos(\omega(t - t_0)) + Z_0 I_{L0} \sin(\omega_0(t - t_0))$$

Integration rules

$$\int_a^b f(x) dx = \int_A^B f(g(t)) g'(t) dt \text{ if } a = g(A), b = g(B) \text{ and } g \text{ is monotone in } [A, B]$$

$$\int_a^b \sin(x) dx = [-\cos(x)]_a^b$$

$$\int_a^b \cos(x) dx = [\sin(x)]_a^b$$