

TSTE12 Design of Digital Systems

Lecture 5: The LIPS project model

Kent Palmkvist

Agenda

- Why projects?
- LIPS project model
 - Phases
 - Organization
 - Roles
 - Documents
 - Milestones/tollgatesractical issues

Project hints

- Weekly meetings
 - Report progress + spent time to me by mail
 - Must have at least one meeting each week.
 - Email must be sent no later than 2 days after the meeting
- You must keep track of the amount of time spent on the project (and on what!)
 - Keep a personal diary where you note project work (hours spent + what type of work)

LIPS Project Management

Material in this presentation has been taken from

LIPS - level 1, version 1.0

Lätt Interaktiv Projektstyrningsmodell

(Easy to use Interactive Project steering)

Linköping Interaktive Project steering

Project model developed as part of the CDIO initiative, an education framework for the next generation of engineers. CDIO developed in cooperations with MIT, KTH, CTH etc.

See <http://www.cdio.org> for more information on CDIO

LIPS Documentation

- LIPS project model
 - Studentlitteratur, ISBN 9789144075266 (out of print)
 - Previously available as local print
 - Swedish version also available
- LIPS introduction and templates
 - <http://www.lips.isy.liu.se>
 - Includes introduction and templates
- Check course specific requirements regarding file formats (at least for TSTE12 and TSTE17!)

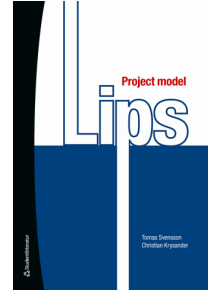

What is a project?

- Start and End
- Limited amount of resources
 - Manpower
 - Funding
 - Time
 - premises
- Well defined task and measurable goals
- Guided by a project manager

Why are projects necessary

- Systems are too complex to be designed by a single person
- Product design and implementation requires expertise in many areas
- Short time to market requires groups of people working in parallel with the product

Project properties

- Usually executed only once
- A new organisation for each project
- A resource owner/sponsor decides on project continuation
- A project plan defines goals, resources, time plans, expected results etc.

Project Models

- Most larger companies have their own
 - PROPS (Ericsson)
 - PSM (SAAB)
 -
 - LIPS (LiTH)
- Often described as a map

LIPS Project Management

- Development model
 - Describe a design path
 - Which tools (and conversion scripts etc) are going to be used for the different tasks?
 - Coding style, Directory structure
 - Verification method
 - Version control system
- Project model
 - Rules for project execution
 - Activities
 - Organisation
 - Documents to produce
 - Checkpoints
 - Supervision
 - Communication within the project

Development model vs Project model

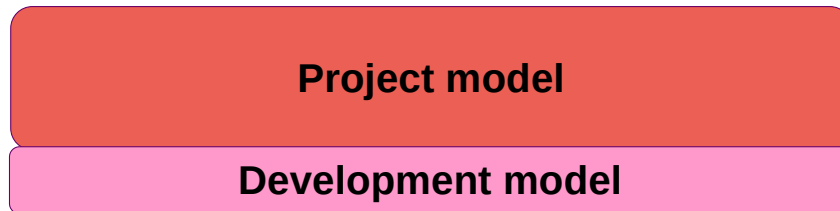

Project Model Elements

- Time and Resource plan
- Documents to produce
- Checkpoints (only accepted if a given set of tasks has been completed)
 - Milestones (project internal check point)
 - Tollgates (external decision points)

Overview of LIPS

- The main phases

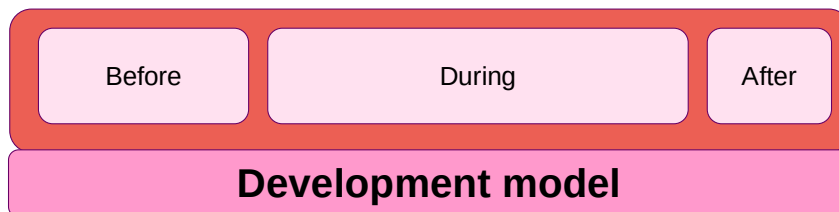

Overview of LIPS

- What shall be done in the different phases?

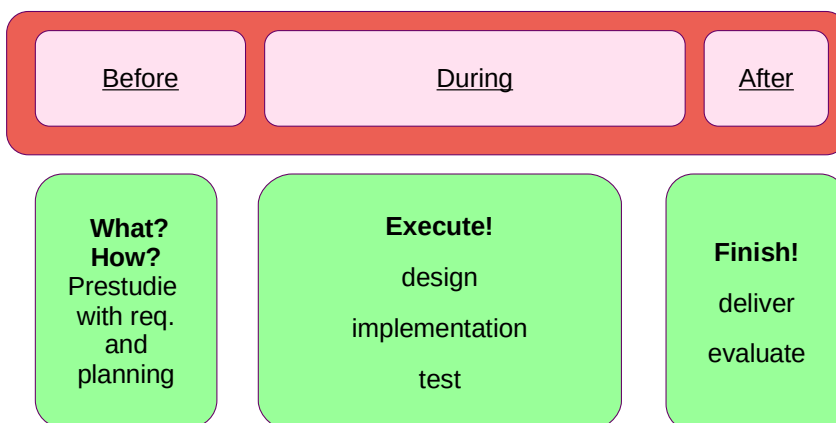

The LIPS Project Model

- How can it be used?
 - scalable in several levels
 - A simple model
 - A medium sized model
 - A full size model
 - For small/medium sized industrial projects
 - Which skills are to be trained in the project?
- Note, the model includes project rules, not work models.

Skills

- To work in a project
- To prepare and perform oral presentations
- To write technical presentations
- To work within given time and cost limits
- To prepare a project plan
 - Time planning
 - Planning of resources
 - Identify activities
- To follow up plans
- To analyse executed work and to change plans
-

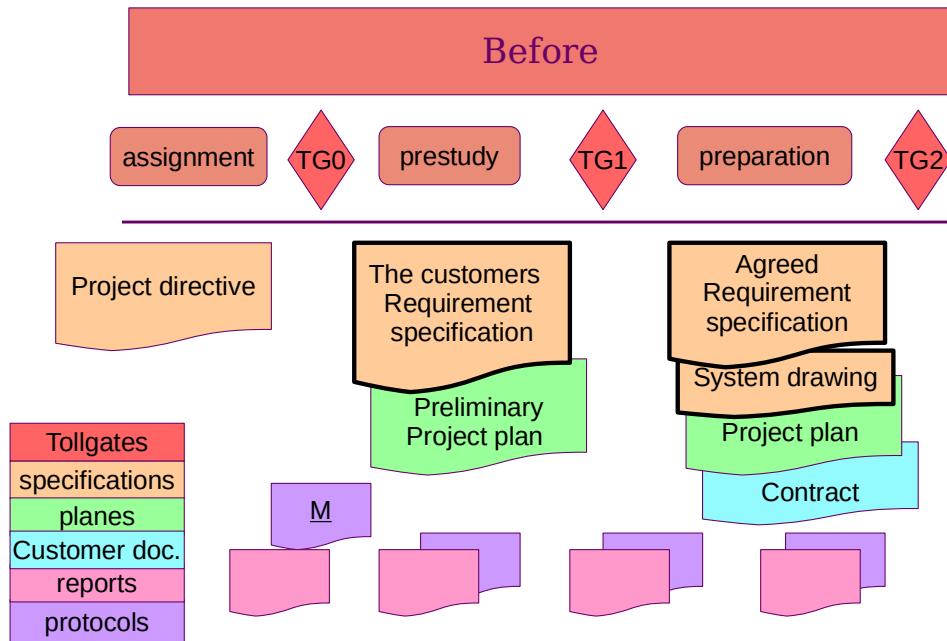
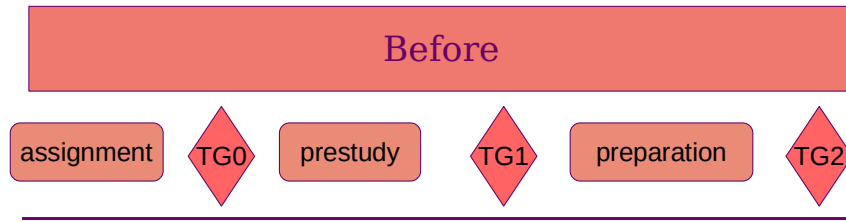

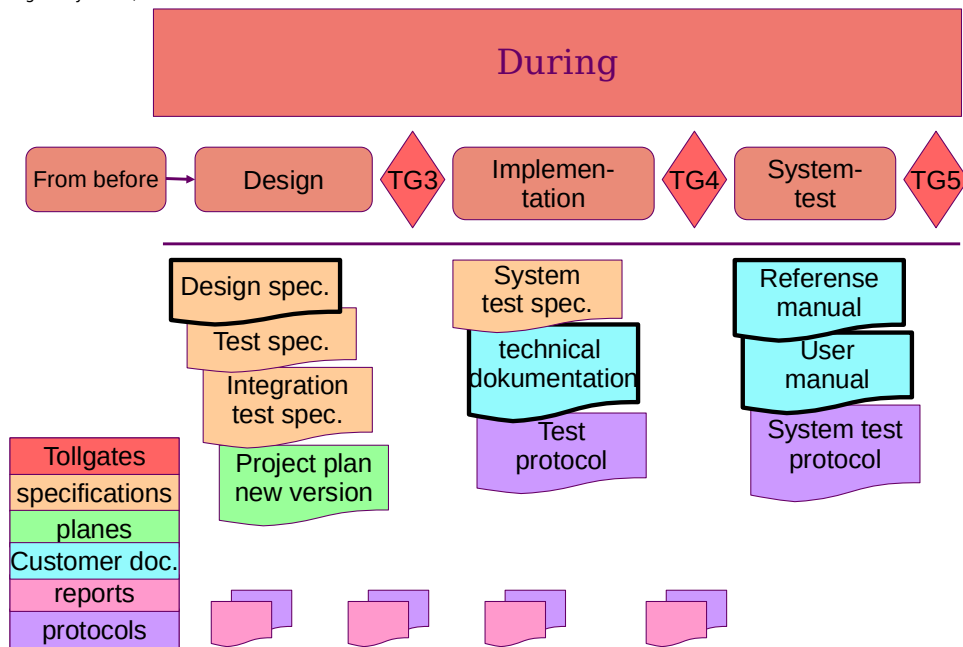
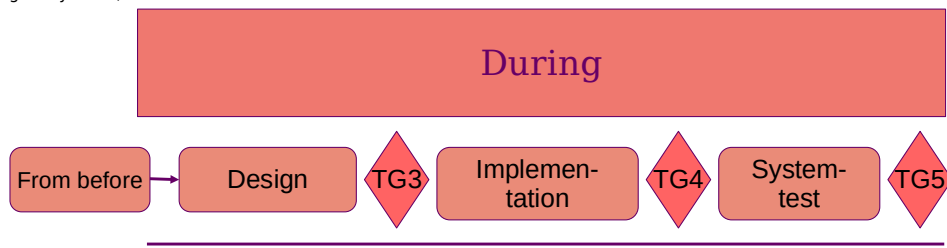

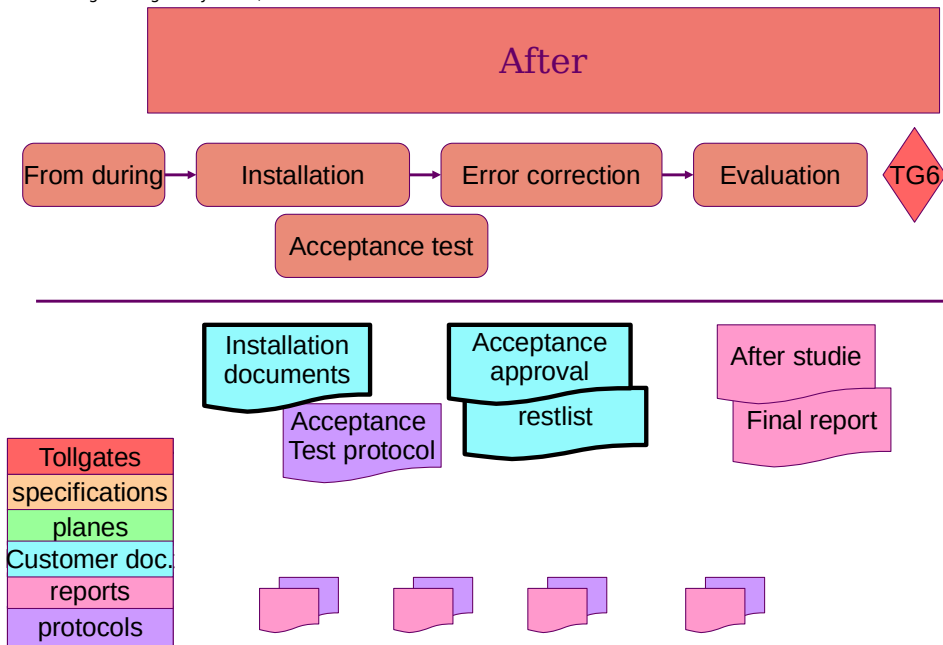
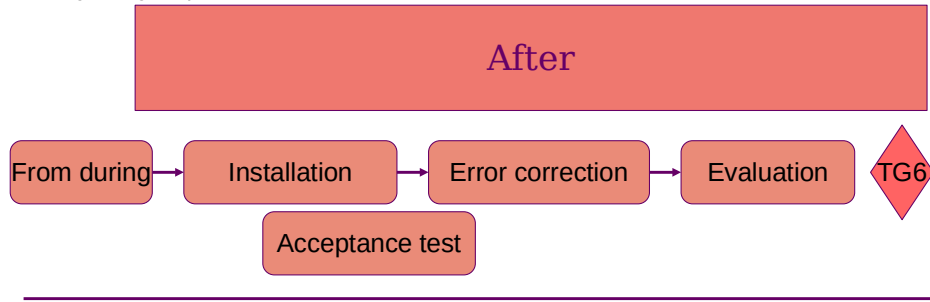

Templates

- Project directive
- Requirement specification
- Project plan
- Time plan
- Meeting minutes
- Status report
- TG meetings
- Technical documents in general (system drawing, design spec. , test spec. , user manuals, etc.)
- After study (project reflections)

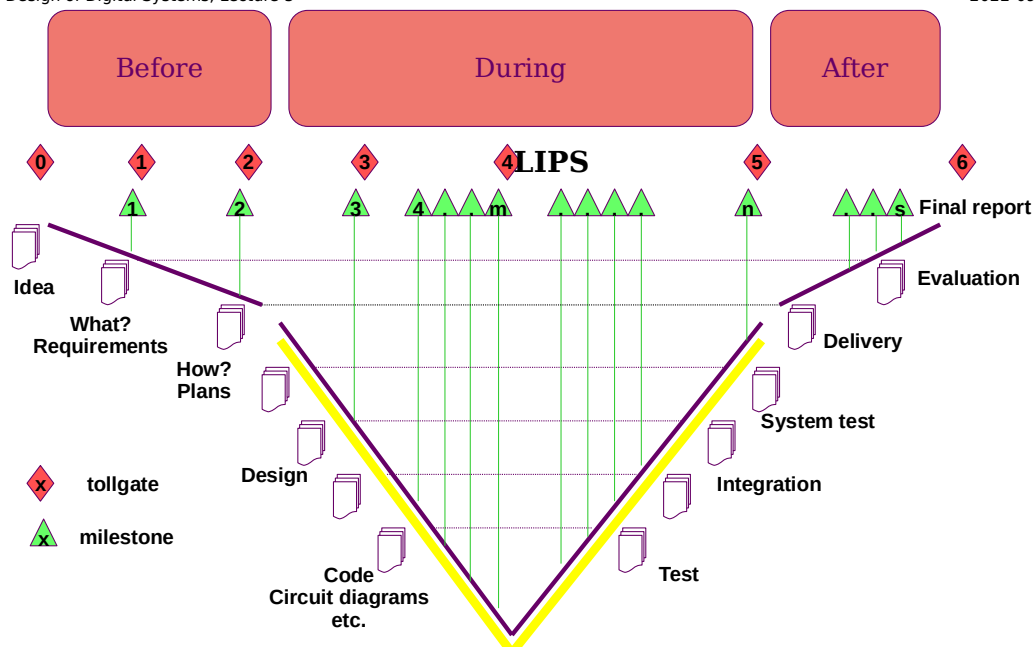

How to execute a project meeting

- Call
 - The project manager calls to the meeting
 - At least x days in advance
 - The invitation shall include an agenda
 - Agenda OK?
 - Walk through the previous protocol
 - Follow the agenda
 - Decide date for the next meeting
- Execute
 - Check presence
 - Who is writing the protocol?
 - Who shall receive the protocol?
- Document
 - Follow the template

Project organisation

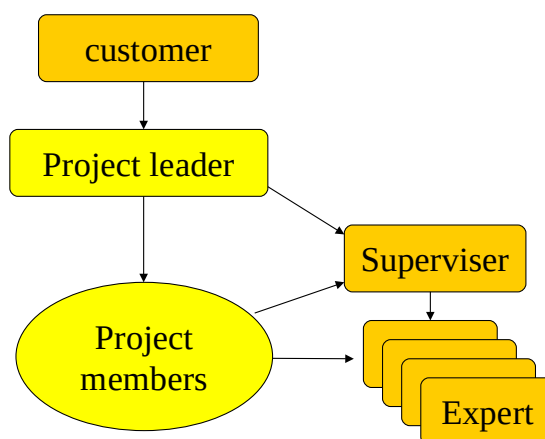

Roles in the project

- Project Leader
- Documentation Responsible
- Test Responsible
- Hardware Design Responsible
- Software Design Responsible
- Delivery Responsible

Roles in the Project Group

- Project Manager
 - Planning (time and resources)
 - Project meetings
 - Keep the design group well informed and motivated
- Documentation
 - Coordinate documentation
 - Define documentation management rules

Roles in the Project Group

- Technical/Design
 - Overall view
 - Specification
 - Unsolved problems
 - Take decision of implementation methods, architectures etc
- Customer relation
 - Keep in touch with the customer
 - Interpret requirements

Roles in the Project Group

- Quality
 - Develop procedures for quality
 - What documents to review and by who
- Test
 - Plan tests activities and resources
 - Define criterias for accepted tests
- Designers
 - Subblocks and/or development stages

Design and Document Management

- Templates
- Version handling
- Computer tools
- Support for multiuser design projects

Requirement Specification

Describes **what** is carried out in the project!

It is important that the customer and the project members agree on how the requirement specification shall be interpreted and how the requirements are verified at delivery.

No requirements can be altered or removed unless both parties agrees on this.

Requirement Specification

Hierarchical structure

- Introduction
 - the projects purpose, partners, definitions
- Overview of the system
 - understand the overall description, subsystems and deliverables
- Subsystem 1-n
 - detailed description of the subsystems
- Various general requirements
 - performance, upgrading capability, economy,
 - deliverables, documentation, education

Requirement Specification

- Introduction
 - Coarse description of the product in its environment (text and graphics)
 - Define how the requirements are described
 - Priorities
 - Parties
 - Goal with the product
 - Usage
 - Background information
 - Definitions

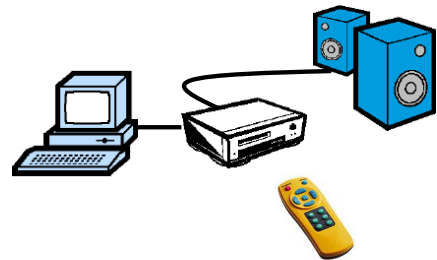

Requirement # x	Change	Requirement text for requirement # 1	priority
-----------------	--------	--------------------------------------	----------

Specifying a Requirement

- All requirements have a unique number
- Requirement text should indicate a measurable requirement
 - Avoid “as good as possible” and similar
 - Avoid multiple requirements combined into one
- Priority used to indicate requirements that may be skipped if time not available

Requirement # x	Change	Requirement text for requirement # 1	priority
-----------------	--------	--------------------------------------	----------

Requirement Specification

- Overview of the system
 - One figure that illustrates the product and its parts
 - Course description of the product
 - Product components (deliverables)
 - Dependencies on other systems
 - Included subsystems
 - Limitations
 - Design filosofi
 - Generic requirements on the complete system

Requirement Specification

- Description of the subsystems
 - One picture illustrating the subsystem and its interface
 - Description of the subsystem
 - Description of the interface
 - Description of the user interface
 - Design requirements
 - Functional requirements on the subsystem

Requirement Specification

- Other requirements
 - Performance requirements
 - Requirements on possibility to upgrade
 - Requirements on reliability
 - Economical requirements
 - Safety requirements
 - Delivery requirements and partial deliveries
 - Documentation requirements
 - Education
 - Quality requirements
 - Supportability

System drawing

Describes **how** the product should be designed

Project plan

Describes **how** the project should be executed

Time plan

Describes **when** activities should be executed and by who

System drawing

- Should be used to identify activities in the project
- Should show what modules the design can be partitioned into
- The smaller parts the design can be partitioned into, the easier will the time estimation be
- Collect all ideas about the design here (even contradictory).
Design decisions are not taken now!
- What are the critical parts of the design?
- Do we need to create a prototype or a test before the design?

Outline of a system drawing

- Introduction
 - What shall be designed
- Overview of the system
 - Block diagram, identify subsystems and interfaces,
 - modularity, possibility to upgrade
- Subsystem 1-n
 - Describe how the subsystems are designed

System drawing - introduction

- What shall be designed
- General view of the end result
- Example from a autonomous robot

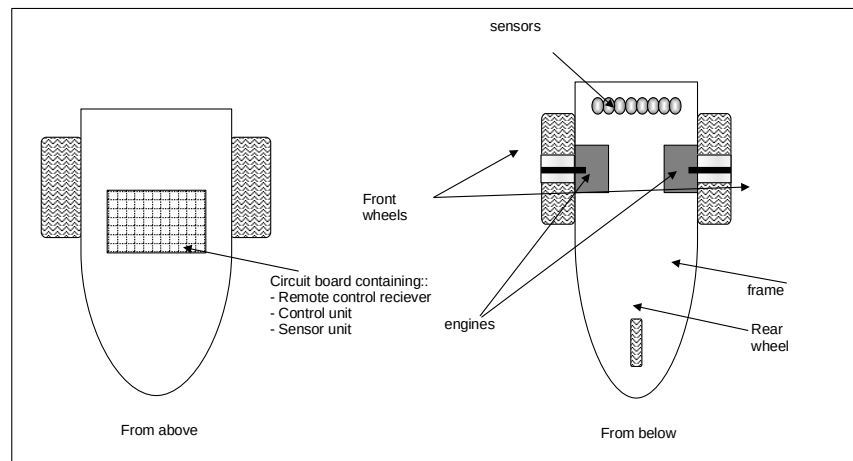
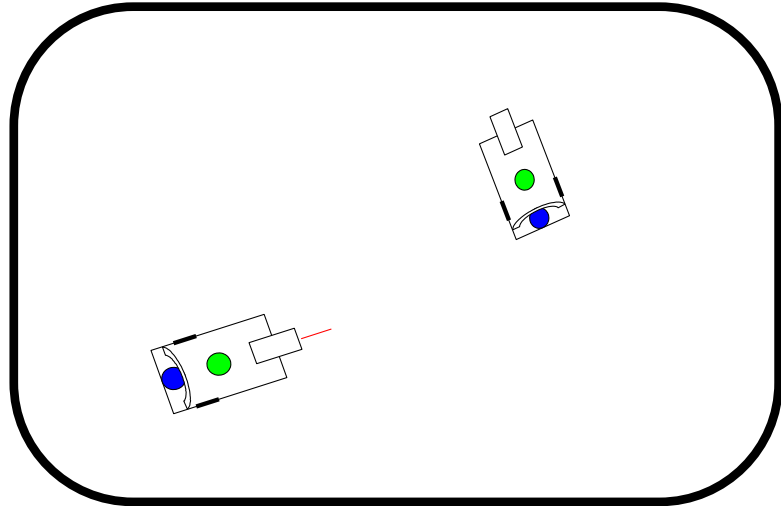

Fig.1 Schematic picture of the car design

System drawing - introduction

- Showing the environment or activity the design should work in
- Example from a combat robot



System drawing - block diagram

- Major building blocks and how they are interconnected

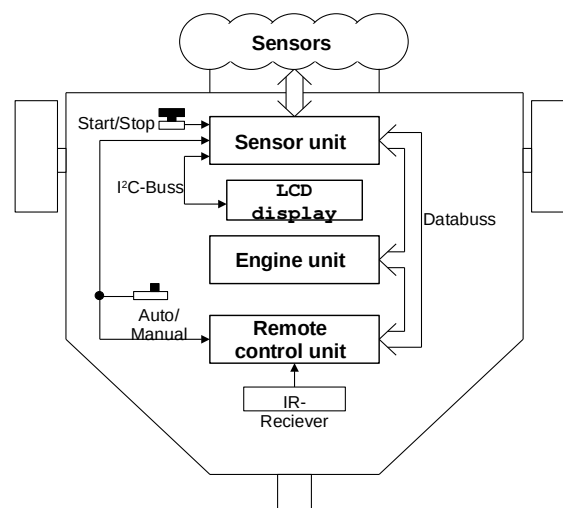

System drawing - block diagram

- More abstract view of the different submodules

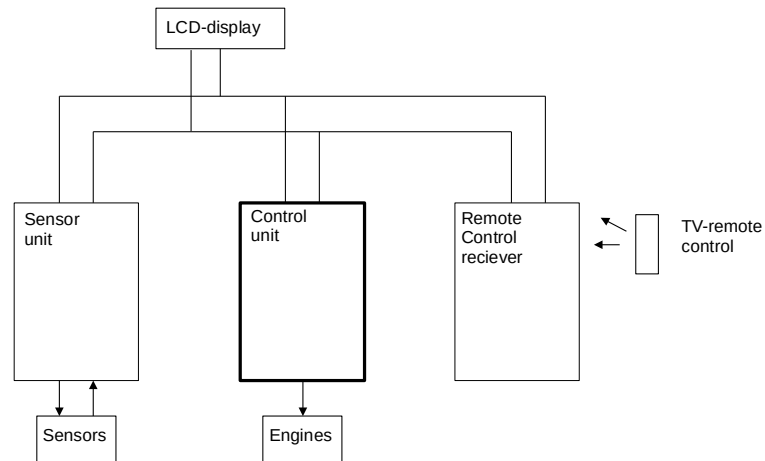

System drawing - one subsystem

- A more detailed sketch of the internals of the module

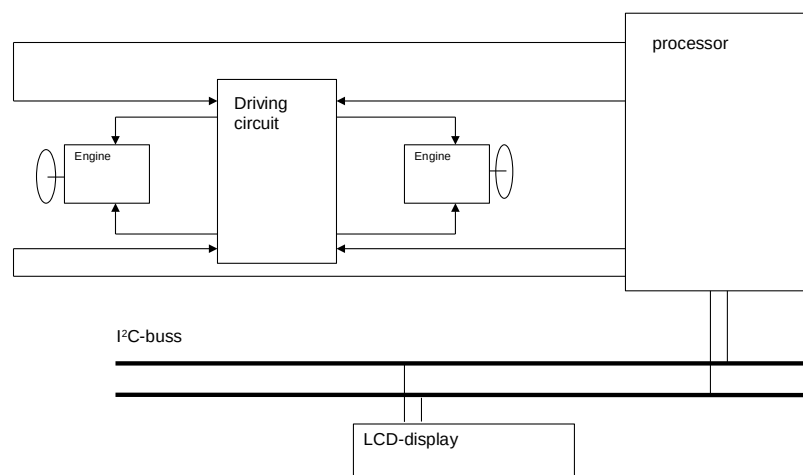

Questions

- What components are there?
- What processor is suitable?
- Interfaces? Are there any good standard busses?
- Sensors?
-

Project plan

The project is guaranteed to fail,
unless it is carefully planned!

Project plan

- Describes **how the project** is carried out
 - One could say that the project plan with appendixes is a specification for the project.
 - The plan shall make it visible to the project members (old and new) and other related parties how the project should be carried out.
 - The plan is dynamic and should at all time describe how the project should be carried out to reach defined goals
 - The project leader is responsible for the project plan

Requirements on a project plan

- Written
- describes
 - What should be done
 - How it should be done
 - Who should do it
 - What resources are needed
 - When should it be done
- Readable by all
- Anticipating – such that unforeseen events can be handled

Project plan

- Example of contents:
 - Project organisation
 - Project goal
 - Resources
 - Completion date and partial deliveries
 - Milestones och tollgates
 - Included documents
 - Reports
 - Meeting frequency
 - Included activities
 - Time plan and resource plan

Contents of a project plan

Below is an example of a header in the LIPS template shown...

Author Name

Version 0.1

Document Version

- All documents have a version number
 - Major.minor (e.g., v0.1, v3.2)
- Major number only incremented when document approved
 - Minor number reset to 0
 - E.g., v0.3 -> v1.0 when document v0.3 approved
- Minor number incremented for every new document submitted

Contents in the project plan 2

Document history

Version	Date	Changes	Sign	Reviewed
0.1	2002-01-17	First draft	ab,cd	as
0.2	2002-07-30	Changed chapter numbers	ab,ck	te

Important to always update history because the plan is dynamik!

Contents of the project plan 3

1. Customer
2. Overview of the project
 - 2.1 Purpose
 - Why is the project executed?
 - What use is it to the customer?
 - 2.2 Goal
 - What is your project goal!
 - 2.3 Deliveries Final delivery and partial deliveries
 - 2.4 Limitations What is not included?

Contents of the project plan 4

3. Phase plan
 - COURSE description of activities included in each phase.
Give an overview!
 - 3.1 Before the project start
 - 3.2 During the project
 - 3.3 After the project

Contents of the project plan 5

4. Organisation plan for the complete project

4.1 Organisation plan (per phase)

(4.2 Organisation plan for the customer)

5. Documentation plan

List the documents that will be produced.

Who is responsible for the different documents.

Who should they be written for and who should they be distributed to.

What is the purpose with each document?

Contents of the project plan 6

6. Development method

Are you going to use any special method?

7. Education plan

Do not forget to add education activities in the activity list

7.1 Internal education

7.2 Customer education

Contents of the project plan 7

8. Report plan

What reports should be written

Who should write them and who should receive them

Plan when they should be written

9. Meeting plan

Make a plan for your project meetings. Give dates or how often they should be held.

Contents of the project plan 8

10. Resource plan

10.1 Persons

You, supervisors

10.2 Material

?

10.3 Workrooms

Telecom lab

10.4 Economy

hours

Contents of the project plan 9

11. Milestones and tollgates

11.1 Milestones

Description of all milestones

11.2 Tollgates

Description of all tollgates

Contents of the project plan 10

12. Activities

A list over the activities that has been identified in the project, and the time they need to execute.

MAJOR PART!

13. Time plan

Describes when an activity should be executed and by who

The time plan is attached in a spreadsheet document.

(14. Change plan)

Ways to describe activities

- List of activities
- Pert
- Gant
- Other

Computer Tools

- Microsoft Project
 - expensive...
- Planner
- Spreadsheets
 - Used here
- Calender
- Webbased

Example of a time plan using LIPS template

- Week by week plan
- Includes all activities, meetings, milestones, and tollgates
- Autosum allocated time and planned time

Planning																												
Project: Design of a walking robot				Date: 1/15/2002				Reviewed:																				
Project group: Yellow production Ltd				Version: 1.0																								
Customer: Tomas Svensson				Author: Pelle Persson																								
Course: Electronics project Y																												
No	Description	TIME	WHO	TIME PLAN (week number)																								
				Hours	Initials	4	5	6	7	8	9	10	11	12	13	14	15	16	17	18	19	20	21	22	23	24	25	26
1	write requirement specification	40	all																									40
2	make a system drawing	15	aa,kk,oo,ss																									15
3	write a project plan	100	all																									100
4	identify activities	8	aa,kk																									8
5	estimate time of activities	8	all																									8
6	resource allocation	4	all																									4
7	make a timeplan	16	pp																									16
8	read more about xx	12	pp,ss																									12
9	investigate technology yy	20	oo,kk																									20
10	write design spec for subsystem1	30	aa,kk																									30
11	write design spec for subsystem2	20	oo,ss																									20
12	modify the project pplan	4	pp																									4
13	design subsystem 1	60	aa,kk																									60
14	design subsystem 2	100	oo,ss																									100
15	integrate and test	30	all																									30
16	write product documentation	60	pp																									60
17	make a project evaluation	4	all																									4
18	project meetings	49	all																									49
19	milestone 1, requirement specification ready																											0
20	milestone 2, project plan ready																											0
21	milestone 3, design specifications ready																											0
22	milestone 4, subsystem ready																											0
23	milestone 5, all deliverables ready																											0
24	tollgate 1, acceptance of requirement specification																											0
25	tollgate 2, acceptance of project plan																											0
26	tollgate 5, acceptance of delivery																											0
Total number of hours				580																								580

Contents of the project plan 11

- 15. Quality plan
 - 15.1 Reviews
 - Should code, documents, schematics, presentation etc. be reviewed? If so, specify how.
 - 15.2 Test plan
 - What tests should be executed and when?
- (16. Risc analysis)

Contents of the project plan 12

17. Priorities

What is more important in case of delays?

18. Project close-out

Define how the project is ended

References

Project management

Project management consists of

- planning
- organise
- handle activities
- handle resources

such that a defined goal is fulfilled within given limits of time and resources.

Project management process

- Create activities and schedule these
- Plan personal and resources
- Adjust the schedule
- Convey project information to the project members and customer
- Follow-up the work
- Change the plan!

Feedback

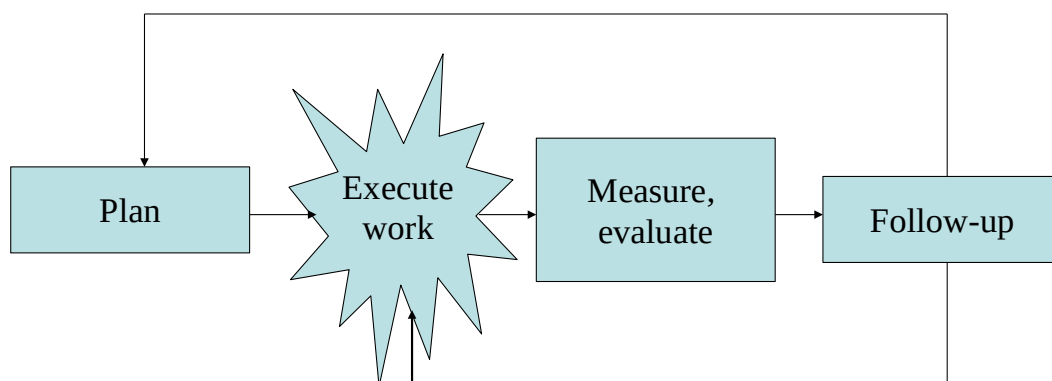

Work in the group

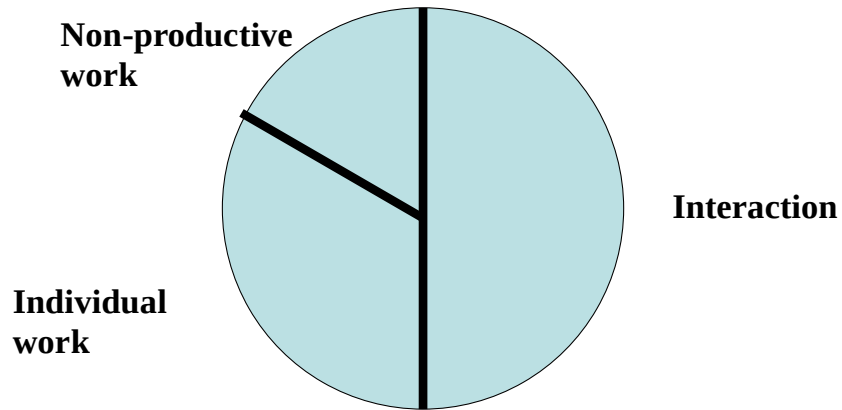

Communication paths in a group

- 3 persons 3 paths
- 4 persons 6 paths
- 5 persons 10 paths
- 6 persons 15 paths

- 10 persons 45 paths

Group members personalities

- Self focused
- Goal focused
- Communication focused
- ?

Project manager

- communicate
 - listen to the coworkers
 - write down what has been said
 - read about project management
- be a helping hand
 - supply coworkers with tools
 - suggest solutions
- distribute work
 - write down who should do what
- plan the work
 - Who is responsible for what?
 - When should it be finished?
 - How much time may it take?
- plan personal
 - when should new coworkers be introduced?
 - teach new coworker
 - possibilities of delays
- report
 - technical and economic status

How to meet new requirements or prerequisites?

- What to do if:
 - The requirement specification is changed?
 - The design is changed?
 - The technical prerequisites are changed?
 - The social prerequisites are changed?
 - Project members gets ill, quits, or fail to complete the task?
 - Errors are made during the project?

Advice for project planning

- Use earlier experiences when estimating time
 - Compare with earlier similar projects
 - Ask experts
- Do not have too long activities
 - Divide into sub activities
- Add spare time
 - At sensitive times during the year
 - At tasks that are difficult to estimate
 - Add a gap after an activity with high risk

More advice for project planning

- Check that the resources are used in the best manner
 - Check that a resource is not used to much
 - Make a resource survey before you distribute activities
- Make a spare plan
- Remake the plan as soon as major changes happens