

VLSI Chip Design Project TSEK06

Project description and requirement specification

Version 1.0

**Project: An 8-Bit Successive Approximation
Analog-to-Digital Converter**

Project number: 5

Project Group:

Name	Project members	Telephone	E-mail
	Project leader and designer 1(5)		
	Designer 2(5)		
	Designer 3(5)		
	Designer 4(5)		
	Designer 5(5)		

Customer and supervisor: Daniel Svård
Office: B building 2D:555, Phone: 013-288946, Fax: 013-139282
Email: svard@isy.liu.se

1 Background

Low-power ADCs are highly demanded in battery-powered or portable communication devices. Successive-approximation (SA) analog-to-digital converters (ADCs) are power-efficient due to its simple architecture with only one comparator in the whole system. This document describes the design specification of a low-power 8-bit SA ADC at a sampling rate of 1-MS/s.

1.1 Project goal

The project goal is to design an integrated circuit (IC) in complementary metal-oxide semiconductor (CMOS) technology. Students, participating in this project as project members and project leaders, should learn the different steps of the IC design flow. That includes the given system architecture analysis, simulation, layout implementation and verification. In the project, students have an optional choice to manufacture the designed IC circuit on a chip. To test the manufactured chips, another course (TSEK11) is available after the project.

1.2 Milestones and deadline

1: Project selection	Week 4
2: Pre-study, project planning, and discussion with supervisor	Week 5
3: High-level modeling design and simulation result (report)	February 17
4: Gate/transistor level design and simulations result (report)	March 14
5: Layout, DRC, parasitic extraction, LVS, post-layout simulations, modification and chip evaluations.	May 12
6: DEADLINE , Delivery of the completed chip.	May 19
7: DEADLINE , Final report, and oral presentation	May 23

1.3 Parties

The following parties are involved in this project:

- 1- Customer: Daniel Svärd
- 2- Project supervisor: Daniel Svärd

Tasks:

- Formulates the project requirements.
 - Provides technical support.
 - Reviews the project documents.
- 3- Project leader: One of the members in the design team.

Tasks:

- Responsible for organization of the team and the project planning.
- Divides the design and documentation work in an efficient way.
- Organizes the team meetings as well as the meetings between the team and supervisor.

- Keeps the supervisor informed about the progress of the project (**at least one email or meeting per week**).
- 4- Project design members (including the project leader)
- Are equally responsible for project planning and design.
 - Participate actively in all the meetings.
 - Support the team and the project leader.
 - Keep the team and project leader informed about the progress of their tasks.

2 Project description

2.1 Basic understanding of SA ADC

A single-ended SA ADC, shown in Figure 1, consists of a sample-and-hold (S/H) circuit, a digital-to-analog converter (DAC), a comparator, and a successive approximation register (SAR). It is designed based on the binary-search algorithm.

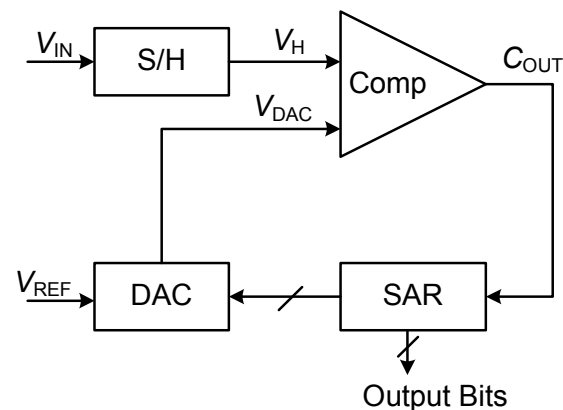

Figure 1: Block diagram of SA ADC

Figure 2 shows an example of the timing diagram for an 8-bit SA ADC. At the first clock cycle, the input voltage is sampled by the S/H circuit, and both the SAR and the DAC are in reset phase. The conversion starts from the most-significant-bit (MSB) at the second clock cycle. The SAR makes a guess '1' for the MSB and sends the digital information to the DAC. The DAC outputs a voltage of $V_{REF}/2$ accordingly. Then the comparator does the comparison between the hold voltage V_H and the DAC output V_{DAC} . At the next conversion cycle for MSB-1, the SAR loads and stores the previous decision for MSB and again makes a guess '1' for MSB-1. The digital word sent to the DAC contains both the previous decision and the current guess. As the clock cycles increase, the output of the DAC successively approximates the sampled voltage. One bit is obtained per clock cycle.

The SAR control logic is a sequential finite state machine, which generates the approximation sequence of 9 steps, given by Table 1. As explained above, step 0 is the sampling step. For the generic step ($s = 1 \dots 8$), three operations are performed: 1) it makes a guess '1'; 2) it loads the decision bit from the comparator; 3) it stores the determined bit which generated at $s-1$ step.

8-bit Successive Approximation ADC

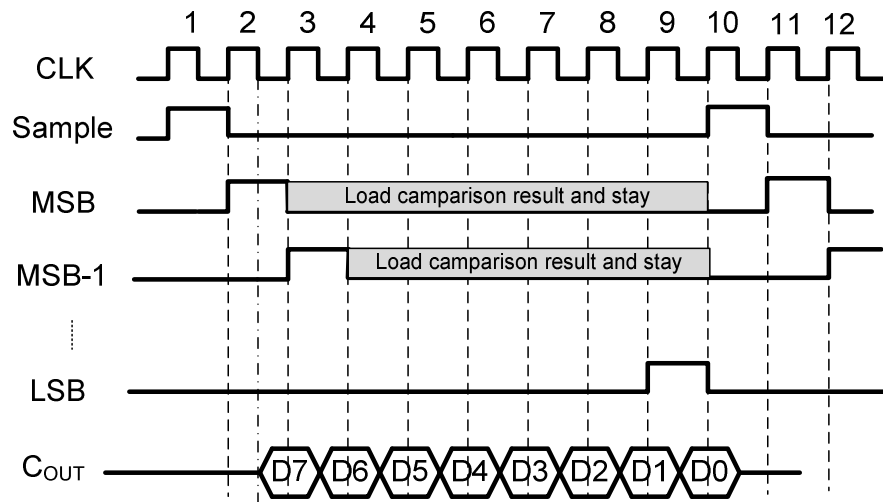

Figure 2: Timing diagram of 8-bit SA ADC

Table 1: SAR algorithm for 8-bit ADC

Step	SAR								Sample	C _{OUT}
0	0	0	0	0	0	0	0	0	1	-
1	1	0	0	0	0	0	0	0	0	D7
2	D7	1	0	0	0	0	0	0	0	D6
3	D7	D6	1	0	0	0	0	0	0	D5
4	D7	D6	D5	1	0	0	0	0	0	D4
5	D7	D6	D5	D4	1	0	0	0	0	D3
6	D7	D6	D5	D4	D3	1	0	0	0	D2
7	D7	D6	D5	D4	D3	D2	1	0	0	D1
8	D7	D6	D5	D4	D3	D2	D1	1	0	D0

2.2 System description

In this project, a differential SA ADC, shown in Figure 3, will be implemented in order to have good common-mode noise rejection. Moreover, the capacitive DAC also realizes the sample-and-hold function to save power.

The DAC is implemented with a binary-weighted capacitive array and it follows the charge-redistribution principle during conversion. The comparator is implemented with a dynamic latch circuit in order to avoid static bias current, thereby further reducing the power consumption.

8-bit Successive Approximation ADC

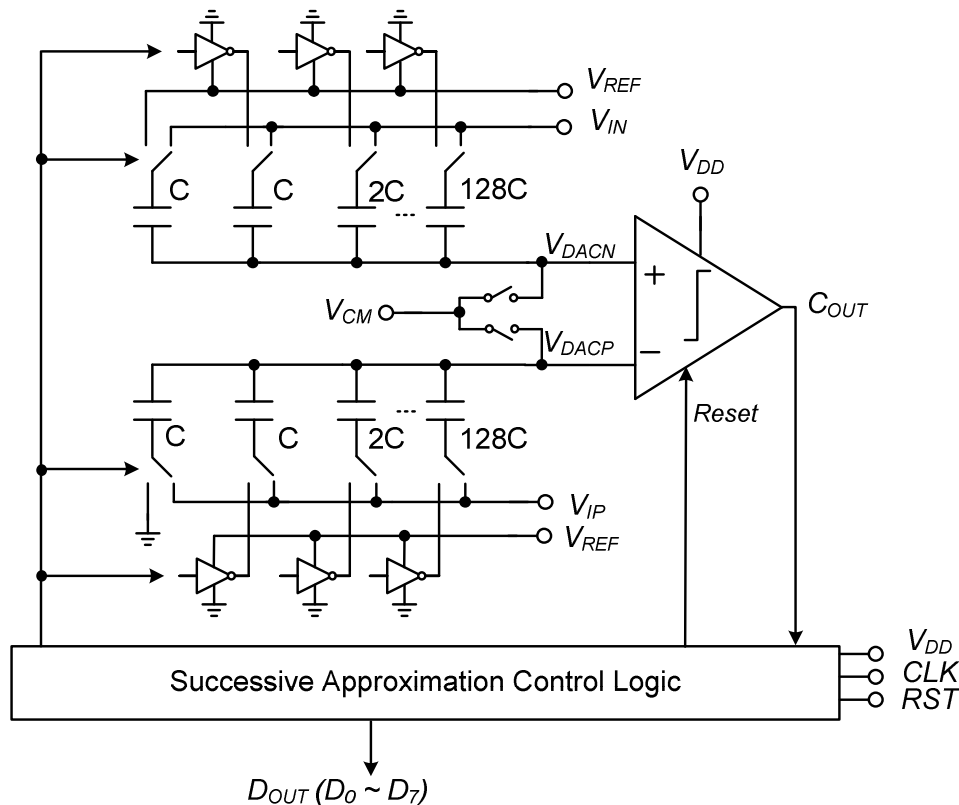

Figure 3: Block diagram of an 8-bit differential SA ADC

2.3 Important design metrics

The ADC should be designed for a sampling frequency of at least 1 MHz and it is aimed for low-power application. Moreover, the performances of the ADC need to be evaluated.

Important things to be considered are:

- Errors caused by sampling
- Matching of the capacitive DAC
- Speed and resolution of the comparator
- Total time budget of the ADC
- Power consumption of the ADC
- Testing of the ADC

3 Area and performance requirements

Table 2 summarizes the circuit performance requirements. Each requirement has its number, formulated text, and the given degree of priority. Three degrees of priority are used: high, medium, and low. High is a firm requirement with no possibility of relaxation, while medium requirements can be relaxed somewhat after good motivation.

Table 2: Circuit performance requirements

Requirement	Requirement text	Priority
1	Sampling frequency at least 1 MHz	High
2	Evaluate the performance of ADC	High
3	Low power optimization	Medium
4	Layout matching	High
5	Integrate as many system components as possible on-chip	High
6	Schematic and layout must be verified by simulation	High
7	Chip core area $< 0.27\text{mm}^2$ (shown in Figure 4)	High
8	Total project pin count ≤ 11	High
9	Design technology is AMS 4-Metal $0.35\mu\text{m}$ CMOS	High
10	The most important system nodes should have off-chip access pins	Low
11	On-chip current densities $< 1 \text{ mA}/\mu\text{m}$	High
12	All requirements fulfilled in “ <i>typical</i> ”, “ <i>slow</i> ”, and “ <i>fast</i> ” process corners and for temperatures between 25°C and 110°C	Medium

3.1 Available resources

- Scientific publication database (available from LiU):
- IEL – IEEE/IEE Electronic Library, <http://www.bibl.liu.se/english/databas/>

3.2 Tools

- Circuit simulation and layout tools from Cadence[®], <http://www.cadence.com/>
- Digital signal processing tools from Matlab[®], <http://www.mathworks.com/>

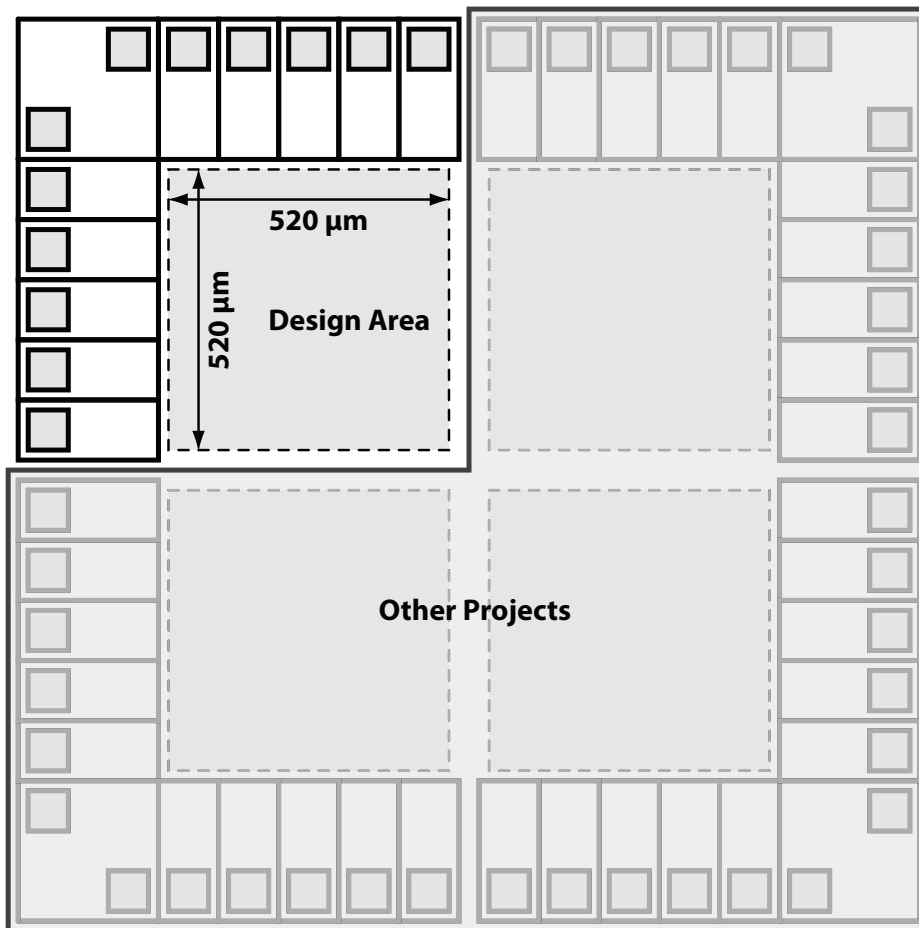

Figure 4: Schematic picture of a 3mm² chip highlighting one corner with 10 generic pads, one V_{DD} and one V_{SS} pad (total 12 per group). Four groups will then share one chip.

4 References

- Maxim, “Understanding SAR ADCs”, Application Note 1080, Mar 01, 2001.
- K. H. Lundberg, “Analog-to-Digital Converter Testing,” <http://www.mit.edu/people/klund/A2Dtesting.pdf>, accessed: Jan. 2013.
- J.M. Rabaey, A. Chandrakasan, and B. Nikolic, Digital Integrated Circuits, 2nd ed., Prentice Hall, 2003, ISBN 0-13-120764-4.
- B. Razavi, Design of Analog CMOS Integrated Circuits, McGraw-Hill, 1st edition, 1999.

For more literature references consult with your supervisor.