

VLSI Chip Design Project TSEK06

Project Description and Requirement Specification

Version 1.0

**Project: A First-Order Sigma-Delta Modulator
with 3-bit Quantizer**

Project number: 1

Project Group:

Name	Project members	Telephone	E-mail
	Project leader and designer 1(5)		
	Designer 2(5)		
	Designer 3(5)		
	Designer 4(5)		
	Designer 5(5)		

Customer and Supervisor: Ali Fazli

Office: B-house 2D:433, Phone: 013-282794, Fax: 013-139282

Email: ali@isy.liu.se

1 Background

This document describes the design requirement specification of a First-Order Sigma-Delta modulator with a 3-bit quantizer (3-bit ADC). One of the bottlenecks in systems today is the data converters (A/D and D/A) required to move between analog and digital domain. Instead of using an ADC with a large number of bits, which is tough to design because of matching requirements, an oversampled low resolution ADC together with noise-shaping can be used. Sigma-Delta converters are commonly used today when the bandwidth of the input signal is less than 1MHz. The main issue with Sigma-Delta ADCs is the need of oversampling. As one can understand there is of course a limit what we can do in terms of oversampling frequency.

1.1 Project Goal

The project goal is to design an integrated circuit (IC) in complementary metal-oxide semiconductor (CMOS) technology. Students, participating in this project as project members and project leaders, should learn the different steps of the IC design flow. That includes the given system architecture analysis, simulation, layout implementation and verification. The project students have an optional choice to manufacture the designed IC circuit on a chip. To test the manufactured chips, another course (TSEK11) is available after the project.

1.2 Milestones and Deadline

1: Project selection	Week 3
2: Pre-study, project planning, and discussion with supervisor	Week 4
3: High-level modeling design and simulation result (report)	February 11
4: Gate/transistor level design and simulations result (report)	March 11
5: Layout, DRC, parasitic extraction, LVS, post-layout simulations, modification and chip evaluations.	May 6
6: DEADLINE , Delivery of the completed chip.	May 13
7: DEADLINE , Final report, and oral presentation	May 24

1.3 Parties

The following parties are involved in this project:

- 1- Customer: Ali Fazli
- 2- Project supervisor: Ali Fazli

Tasks:

- Formulates the project requirements
- Provides technical support
- Reviews the project documents.

- 3- Project leader: One of the members in the design team.

Tasks:

- Responsible for organization of the team and the project planning.

- Divides the design and documentation work in an efficient way
 - Organizes the team meetings as well as the meetings between the team and supervisor
 - Keeps the supervisor informed about the progress of the project (**at least one email or meeting per week**)
- 4- Project design members (including the project leader)
- Are equally responsible for project planning and design.
 - Participate actively in all the meetings
 - Support the team and the project leader
 - Keep the team and project leader informed about the progress of their tasks.

2 Project Description

2.1 System Description

The complete system to be built should be a working first-order Sigma-Delta modulator. The total system is shown in Figure 1. The main components to be designed are an integrator, a 3-bit flash-ADC, and a 3-bit DAC. The switched-cap integrators require an Operational amplifier (OP). A schematic of a suitable OP will be given to you in order to save some time. The digital filter that is needed after the Sigma-Delta modulator can be done in Matlab when doing chip measurements.

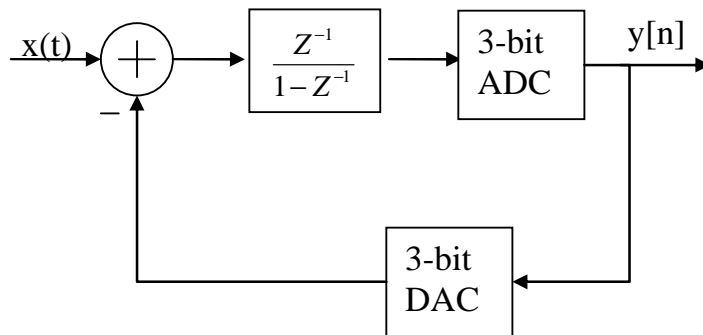

Figure 1: First-order Sigma-Delta modulator architecture.

The target for this design will be to achieve about 55-60dB dynamic range over a 500kHz bandwidth. The dynamic range (SNR=Signal-to-noise ratio) that can be achieved with a first-order Sigma-Delta modulator can be calculated as

$$SNR = 6.02 \cdot N + 1.76 - 5.17 + 30 \log(OSR)$$

Where N is the number of bits from the quantizer, and OSR is the oversampling ratio (the ratio of input bandwidth and the nyquist frequency). Using a sampling frequency of 32MHz ($OSR = 32 \text{ MHz} / (2 * 500 \text{ kHz}) = 32$) gives an SNR of about 60dB. This is equivalent with a 9.6-bit ADC. For a first-order sigma delta modulator an increase of the oversampling ratio by a factor of two means an increase of the equivalent number of bits by 1.5.

2.2 Important Design Metrics

The circuit must be designed for a sampling frequency of at least 32MHz. This will be translated to requirements on the integrators, 3-bit quantizer, and the 3-bit DAC. Important things to consider are:

- Timing, settling, and internal noise in the integrators
- Precision in the ADC
- The structure is also sensitive to settling- and matching-errors in the DAC
- Furthermore, the power-consumption is of large interest and should be minimized.

3 Area and Performance Requirements

The table below summarizes the circuit performance requirements. Each requirement has its number, formulated text, and the given degree of priority. Three degrees of priority are used: high, medium, and low. High is a firm requirement with no possibility of relaxation, while medium requirements can be relaxed somewhat after good motivation.

Requirement	Requirement Text	Priority
1	Sampling frequency at least 32MHz	High
2	Integrate as many system components as possible on-chip	High
3	Schematic and layout must be verified by simulation	High
4	Layout matching	High
5	Simulated chip power consumption < 100mW at max. freq.	Medium
6	Chip core area < 0.27mm ²	High
7	Total project pin count: 12	High
8	Design technology is AMS 4-Metal 0.35μm CMOS	High
9	The most important system nodes should have off-chip access pins	Low
10	On-chip current densities < 1 mA/μm	High
11	All requirements fulfilled in “ <i>typical</i> ”, “ <i>slow</i> ”, and “ <i>fast</i> ” process corners and for temperatures between 25°C and 110°C	Medium

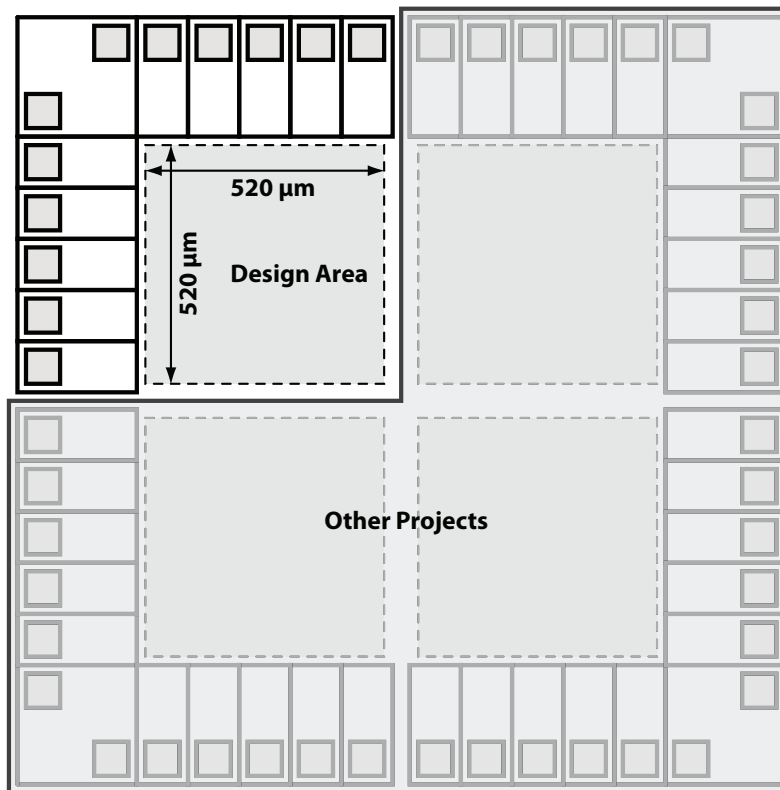

Figure 2: Schematic picture of a 3mm^2 chip with 40 generic pads four V_{DD} and four V_{SS} pads (total 48 pads), which will be shared between a number of projects.

3.1 Available Resources

- Scientific publication database (available from LiU):
- IEL – IEEE/IEE Electronic Library, <http://www.bibl.liu.se/english/databas/>

3.2 Tools

- Circuit simulation and layout tools from Cadence[®], <http://www.cadence.com/>

4 References

- J.M. Rabaey, A. Chandrakasan, and B. Nikolic., “Digital Integrated Circuits”, 2nd ed., Prentice Hall, 2003, ISBN 0-13-120764-4.
- D.A. Johns and K. Martin, “Analog Integrated Circuit Design”, John Wiley & Sons, 1997.
- A 12-mW ADC delta-sigma modulator with 80 dB of dynamic range integrated in a single-chip Bluetooth transceiver; Grilo,J.;Galton,I.;Wang,K.;Montemayor,R.G.; Solid-State Circuits, IEEE Journal of , Volume:37, Issue:3, March2002 Pages:271 – 278
- Delta-sigma data conversion in wireless transceivers Galton, I.; Microwave Theory and Techniques, IEEE Transactions on , Volume: 50 , Issue: 1 , Jan. 2002 Pages:302 - 315

For more literature references consult with your supervisor.