

VLSI Chip Design Project TSEK01

Project description and requirement specification

Version 1.0

**Project: 100MHz, 10dBm direct VCO
modulating FM transmitter**

Project number: 6

Project Group:

Name	Project members	Telephone	E-mail
	Project leader and designer 1(5)		
	Designer 2(5)		
	Designer 3(5)		
	Designer 4(5)		
	Designer 5(5)		

Customer and supervisor: Rashad.M.Ramzan
Office: B-house 2D:449, Phone: 013-288946, Fax: 013-139282
Email: rashad@isy.liu.se

1 Background

This document describes the design requirement specification of a direct VCO modulating FM Radio Transmitter. This simple transmitter can link your home entertainment system to a portable FM radio receive. For example, you can play a CD in your living room and listen to it on a portable radio in back yard.

1.1 Project goal

The project goal is to design an integrated circuit (IC) in complementary metal-oxide semiconductor (CMOS) technology. Students, participating in this project as project members and project leaders, should learn the different steps of the IC design flow. That includes the given system architecture analysis, simulation, layout implementation and verification. The project students have an optional choice to manufacture the designed IC circuit on a chip. To test the manufactured chips, another course (TSEK11) is available after the project.

1.2 Milestones and deadline

1: Project selection	Week 3
2: Pre-study, project planning, and discussion with supervisor	Week 4
3: High-level modeling design and simulation result (report)	February 15
4: Gate/transistor level design and simulations result (report)	March 5
5: Layout, DRC, parasitic extraction, LVS, post-layout simulations, modification, chip evaluations, and delivery of the completed chip	May 9
6: DEADLINE , Final report, and oral presentation	May 23

1.3 Parties

The following parties are involved in this project:

- 1- Customer: Rashad.M.Ramzan
- 2- Project supervisor: Rashad.M.Ramzan

Tasks:

- Formulates the project requirements
 - Provides technical support
 - Reviews the project documents.
- 3- Project leader: One of the members in the design team.

Tasks:

- Responsible for organization of the team and the project planning.
- Divides the design and documentation work in an efficient way
- Organizes the team meetings as well as the meetings between the team and supervisor
- Keeps the supervisor informed about the progress of the project (at least one e-mail or meeting per week)

Direct VCO Modulating FM Transmitter

- 4- Project design members (including the project leader)
- Are equally responsible for project planning and design.
 - Participate actively in all the meetings
 - Support the team and the project leader
 - Keep the team and project leader informed about the progress of their tasks.

2 Project description

2.1 System description

The complete system to be built should include the on-chip audio amplifier, low pass filter (LPF), pre-emphasis circuit (optional), phase detector, VCO (Current Steering amplifier based voltage controlled oscillator) and power amplifier. The off-chip components include microphone coupling circuit and matching circuit (if needed) for antenna.

The core of transmitter is VCO whose centre frequency can be controlled by controlling the current through CSA (current Steering Amplifier) cell. While several oscillator topologies are viable for construction of a practical RF VCO, the one that has proven successful for on-chip design is VCO using three or five stage CSA ring oscillator. This VCO do not need on-chip capacitor or inductor, although its phase noise performance is not as good as conventional VCO using inductor and varactors.

The 2nd most important component of design is power amplifier. The class C type power amplifier is good candidate for this application (Razavi Chap-8). The total system block level diagram is shown in Figure 1.

The matching circuit can be resistor-capacitor circuit for simplicity. The more efficient matching circuits employ both L and C components. The MIC is ELECTRET Microphone with SNR better than 50dB. The headphone-mic set used with sound card of PC can also be used.

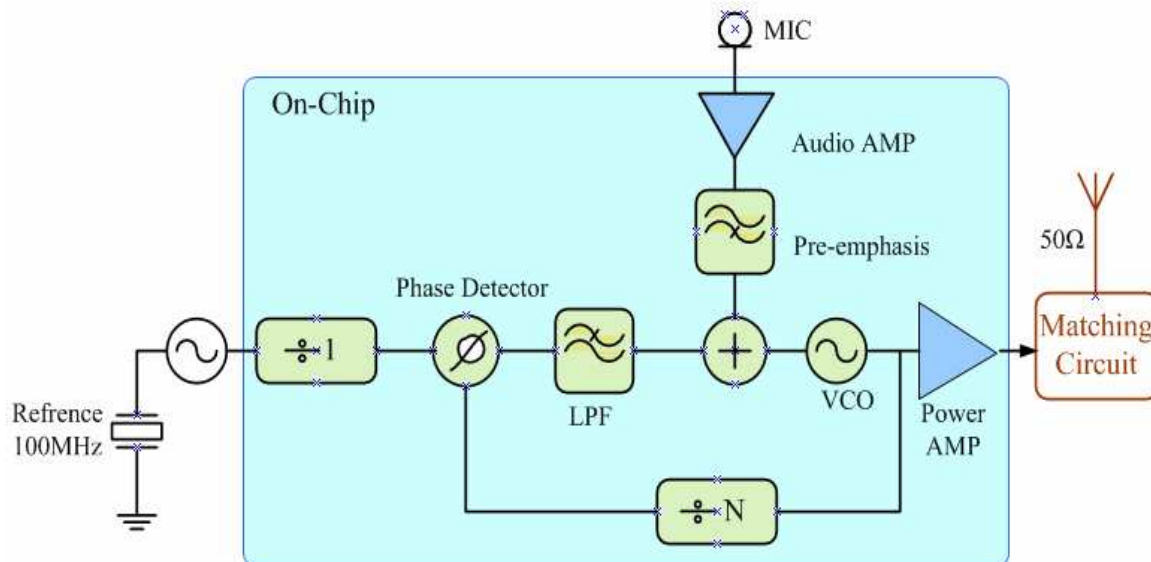

Figure 1: System Block diagram of 100MHz, 10dBm direct VCO modulating FM radio Transmitter.

Direct VCO Modulating FM Transmitter

2.2 *Typical Design Parameters*

- Power Supply 3.3V \pm 5%
- Transmitter Frequency 100 MHz
- Out put Power 10 dBm (10mW)
- Modulation Frequency 100Hz – 5KHz (Audio)
- Frequency Deviation \pm 75 KHz
- Audio Input Sensitivity 0.5V rms for +/- 75 KHz
- Spurious Emissions Better than -45 dBc (with ref to carrier)
- Total Power Consumption \leq 100mW

NOTE – Most countries accept emission of 10dBm in FM band including Sweden. So maximum output power of transmitter is limited to 10 dBm (10mW). This will give more than 100-200 meters of range with clear reception using typical commercial FM receiver. This is solely an educational project and no approval from any regulation agency is required to build and test this transmitter for educational purposes.

3 Area, performance requirements

The table below summarizes the FM transmitter performance requirements. Each requirement has its number, formulated text, and the given degree of priority. Three degrees of priority are used: high, medium, and low. High is a firm requirement with no possibility of relaxation, while medium requirements can be relaxed somewhat after good motivation.

S.No	Requirements	Priority
1	Integrate as many components as possible on-chip	High
2	Schematic and layout must be verified by simulation	High
3	Simulated chip power consumption < 100mW (3.3V supply)	Medium
4	Maximum transistor sizing < 200 μ m	Medium
5	Chip core area < 0.150mm ² (based on 5-6 projects per chip)	High
6	Total project pin count < 10-12 (prepare to share inputs)	High
7	Design technology is AMS 4-Metal 0.35 μ m CMOS	High
8	The most important system nodes should have off-chip access pins	Medium
9	On-chip current densities < 1 mA/ μ m	High
10	All requirements fulfilled in “typical”, “slow”, and “fast” process corners and for temperatures between 25 and 110 °C	Medium
11	Power supply decoupling capacitors	High

Direct VCO Modulating FM Transmitter

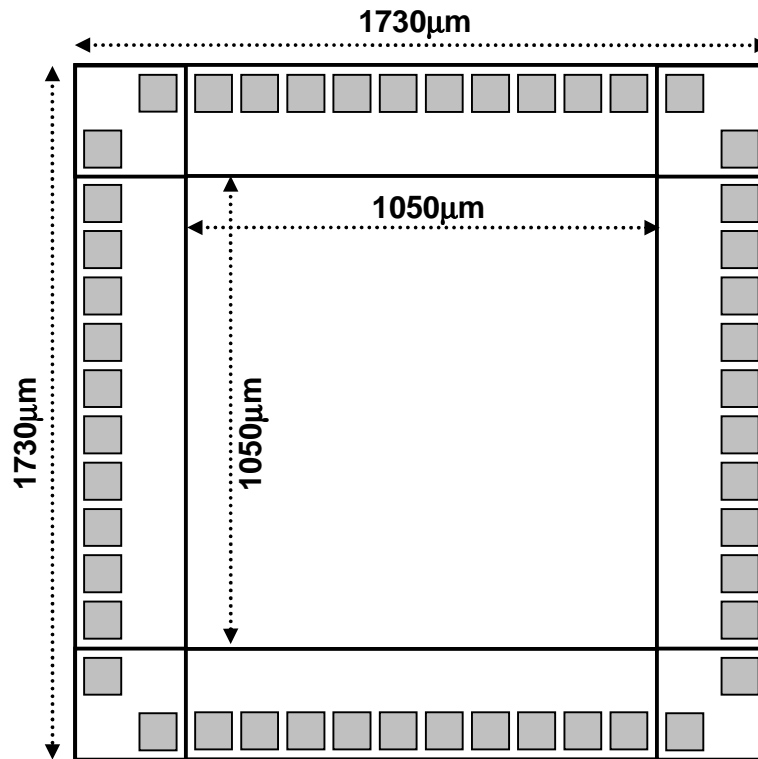

Figure 2: Schematic picture of a 3mm^2 chip with 40 generic pads four V_{DD} and four V_{SS} pads (total 48 pads), which will be shared between a number of projects.

3.1 Available resources

- Scientific publication database (available from LiU):
- ◆ IEL – IEEE/IEE Electronic Library, <http://www.bibl.liu.se/english/databas/>

3.2 Tools

- ◆ Circuit simulation and layout tools from Cadence[®], <http://www.cadence.com/>

4 References

Howard.C.Yang, "A Low Jitter 0.3-165 MHz CMOS PLL Frequency Synthesizer for 3 V/5V operation", IEEE J of Solid State, 1997, Vol.32

Behzad Razavi, "Design of Analog CMOS Integrated Circuits", McGraw-Hill ISBN: 0072380322 (PLL and CMOS amplifier Chapters)

Behzad Razavi, "RF Microelectronics", Prentice Hall PTR, ISBN 0-13-887571-5, 1998 (Power Amplifier and Transmitter Chapters)

It is highly recommended that students taking this project also take the course TSEK02 and TSEK03.

For more literature and references consult with your supervisor.