

TSTE19 Power Electronics

- Lecture 7
- Tomas Jonsson
 - ISY/EKS

Outline

- DC-AC switching inverters
 - Switch-mode principle
 - Single-phase inverter
 - PWM switching
 - Current ripple and commutation

Switch-mode dc-ac inverter

- Sinusoidal ac
- Controlled magnitude
- Controlled frequency
- Common use
 - Ac motor drive
 - Uninterruptable ac power supply
 - 12V DC -> 230V AC inverter

Switch-Mode DC-AC Inverter

- Fixed dc-voltage
- Switched output filtered to generate sinusoidal v_o
- Assume inductive load at v_o , i_o lagging
- Waveforms in all four quadrants

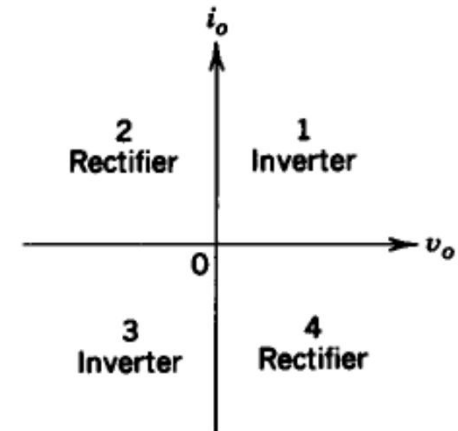
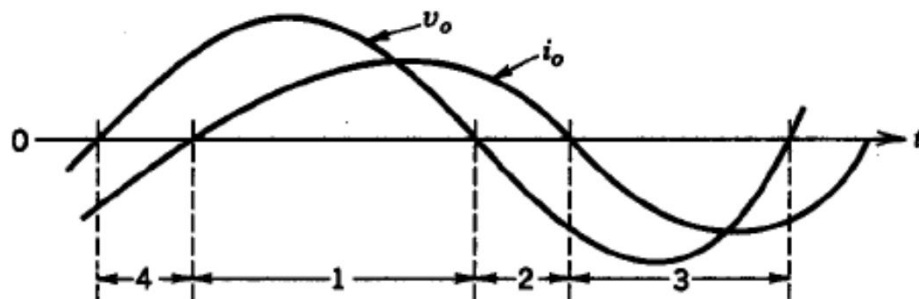
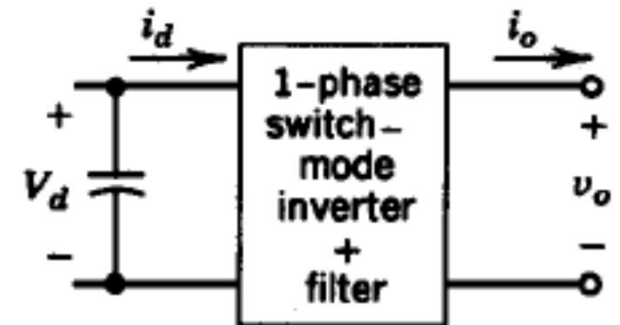

Compare: Step-down (buck) converter

- Output voltage amplitude controlled by switch duty cycle

$$\frac{V_o}{V_d} = D$$

- Uni-directional load current defined by diode, from high voltage to low voltage side

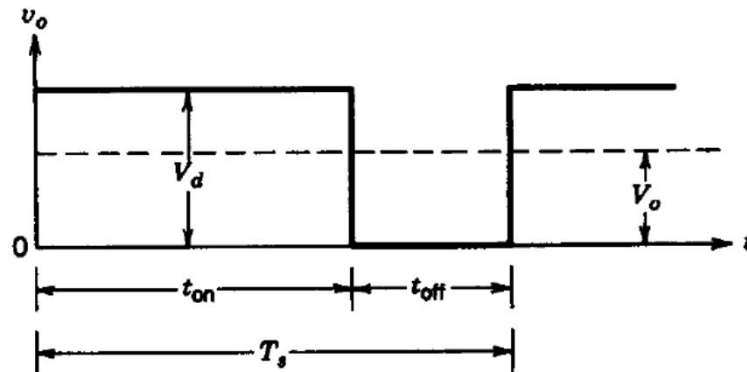
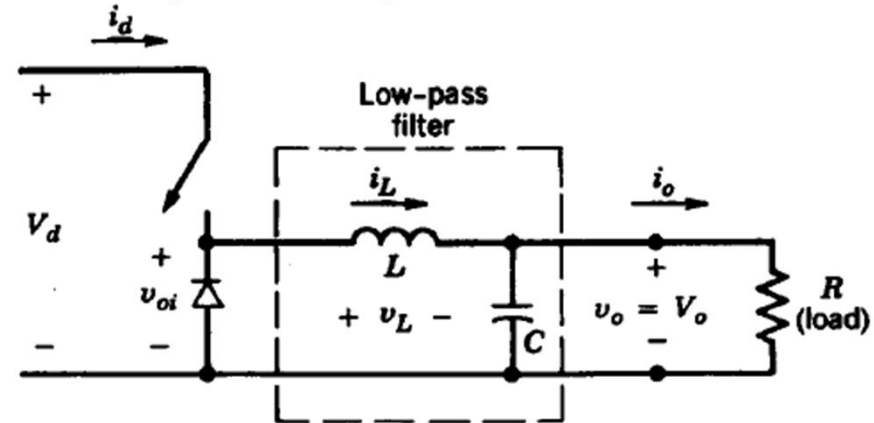

Compare: Step-up (boost) converter

- Voltage ratio defined by duty cycle

$$V_o/V_d = 1 - D$$

- Current from low voltage side to high voltage side

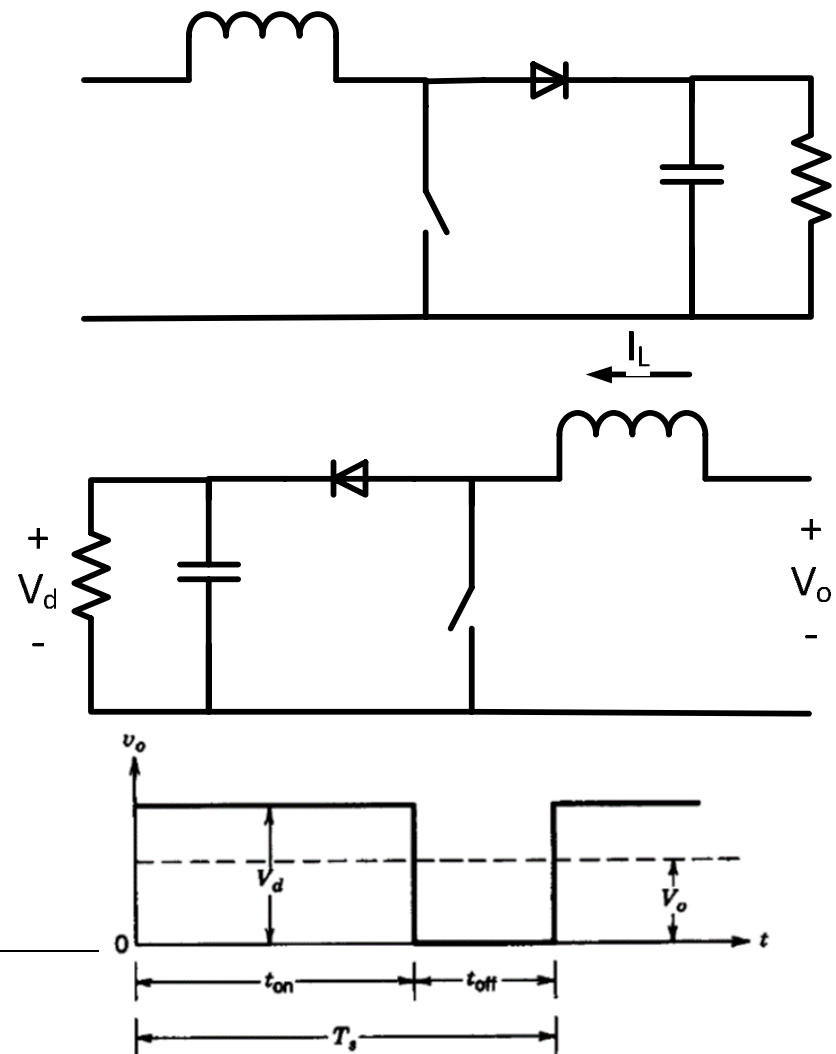

Half-bridge(2-level) converter

- 2 output voltage levels ($V_d, 0$)
- Average voltage magnitude controlled by duty cycle
- Bi-directional current
- Half-bridge converter, a common building block in many switched converter

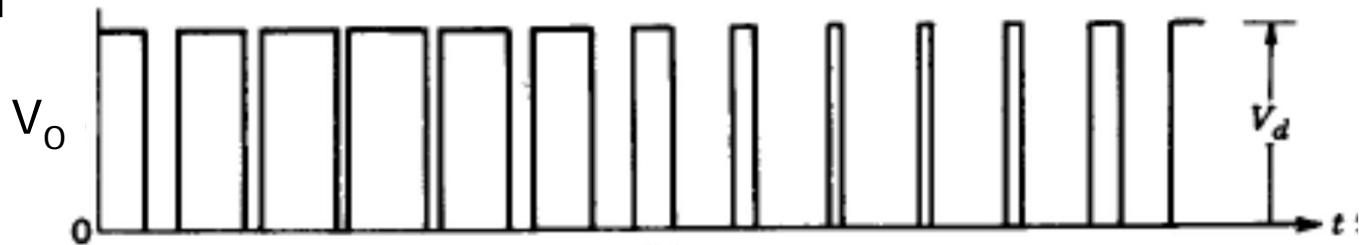
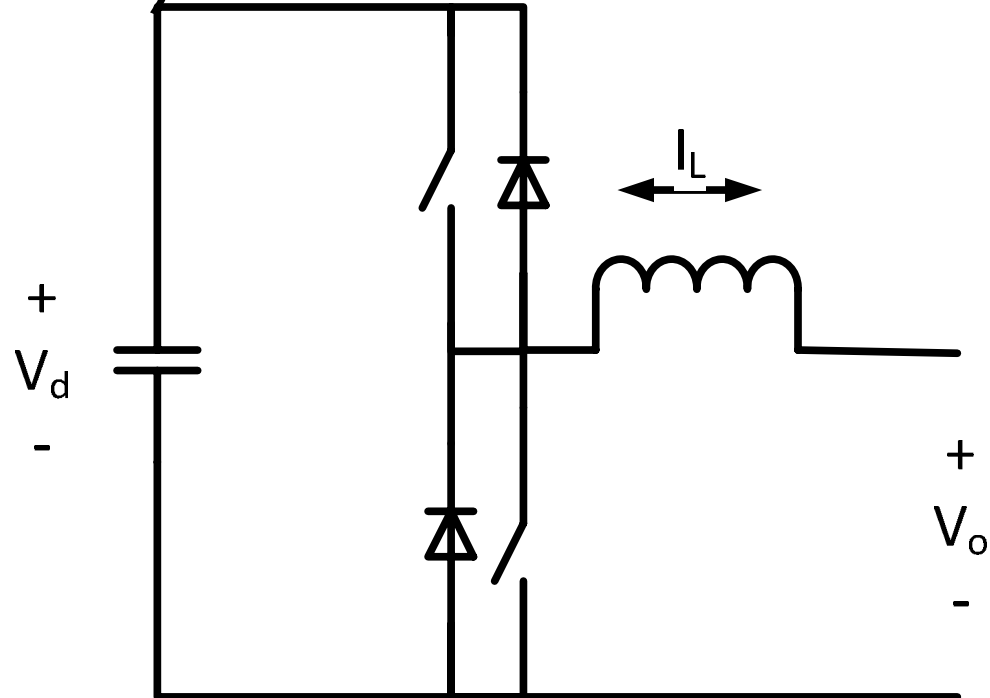

Half-bridge (2-level) converter

- DC-side midpoint '0' reference point for ac-output
- Output voltage switched between $+\frac{V_d}{2}$ and $-\frac{V_d}{2}$

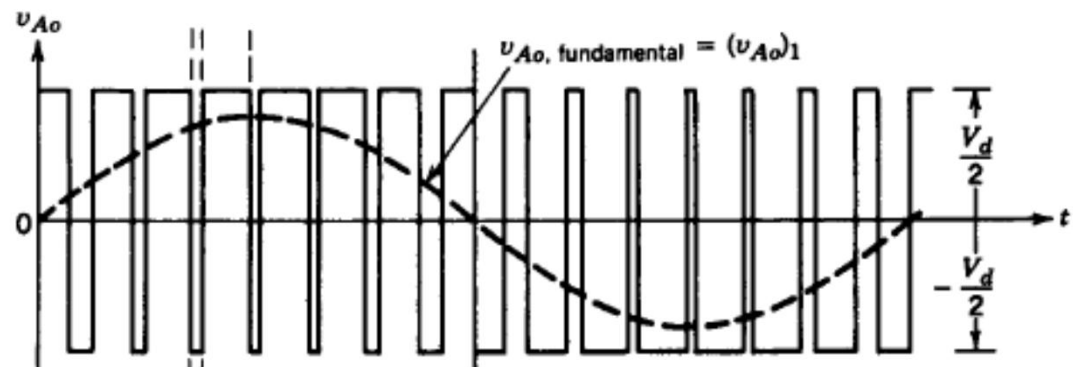
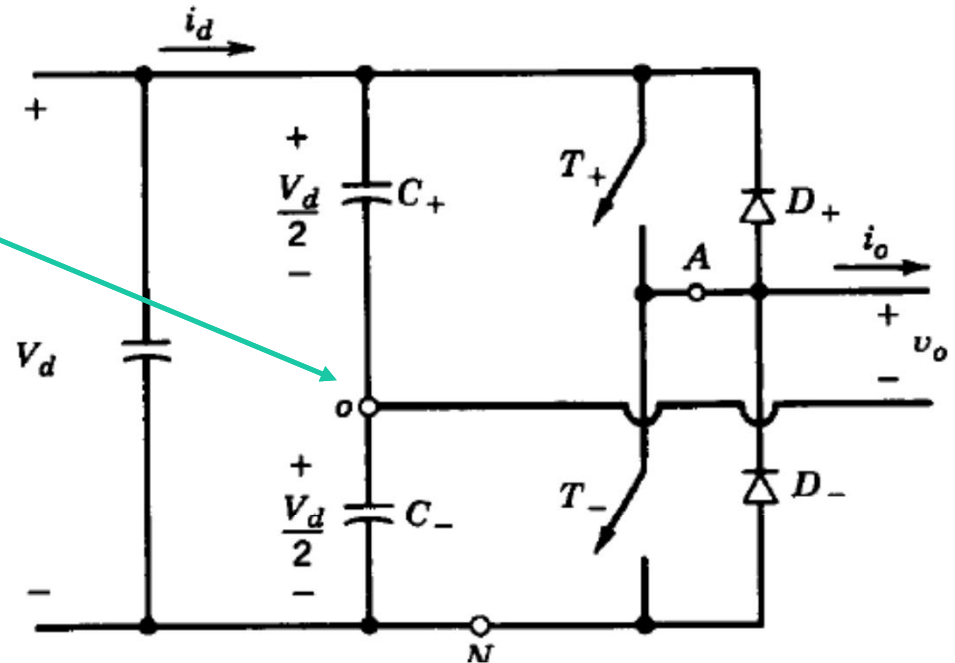

Pulse-width modulated switching scheme

- Constant f_s
- Amplitude modulation ratio

$$m_a = \frac{\hat{V}_{control}}{\hat{V}_{tri}}$$

- Frequency modulation ratio (pulse number)

$$m_f = \frac{f_s}{f_1}$$

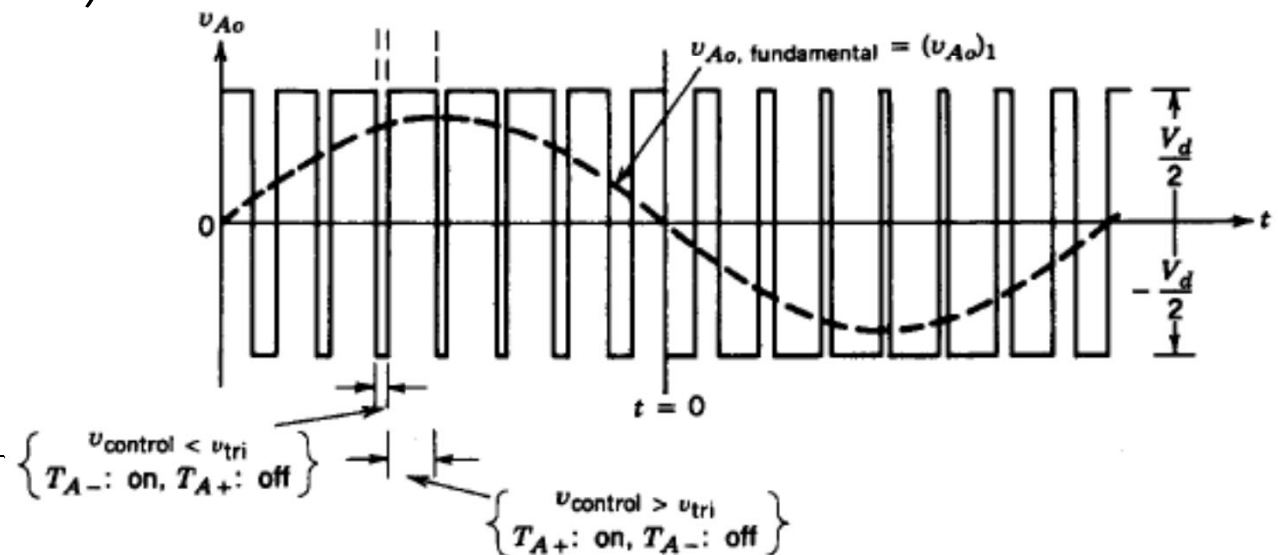
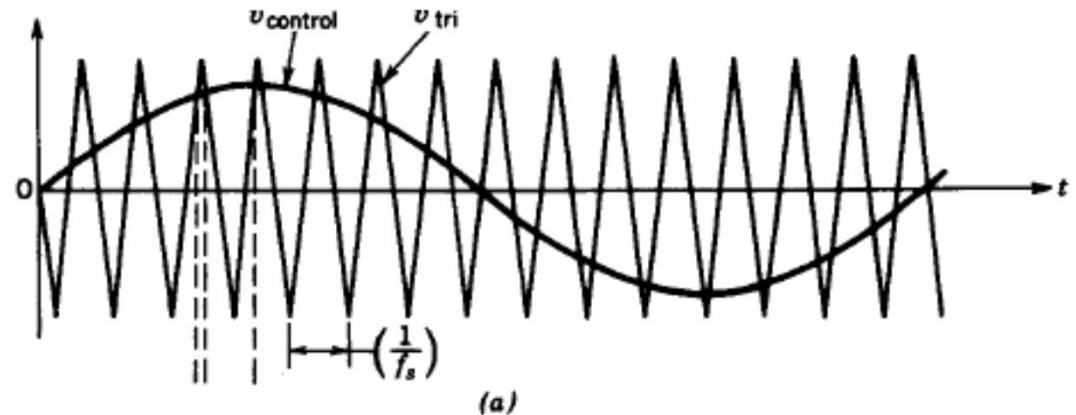

PWM modulation control

- Fundamental frequency output, $\hat{V}_{ao1} \sin \omega_1 t$
- $0 < m_a < 1$, linear range

$$\hat{V}_{ao1} = m_a \frac{V_d}{2}$$

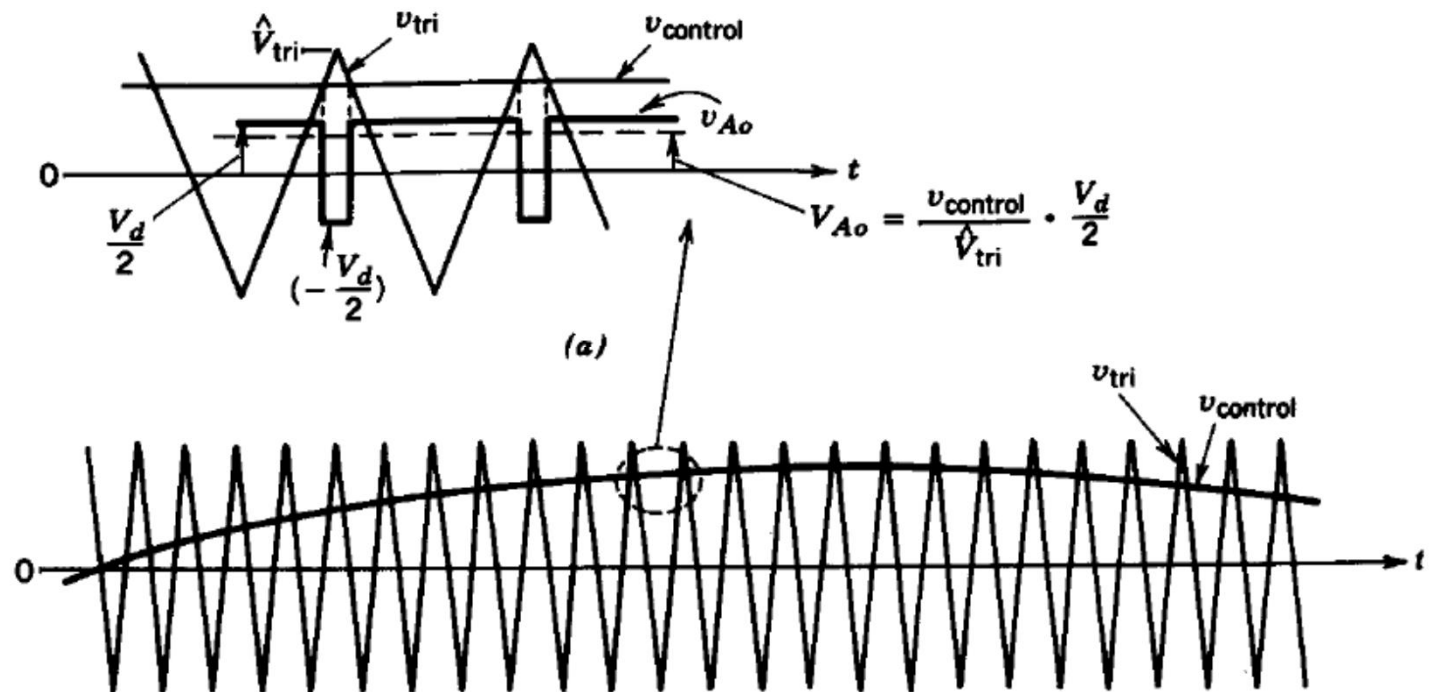

PWM modulation harmonics

- Harmonics as sidebands around multiples of switching frequency

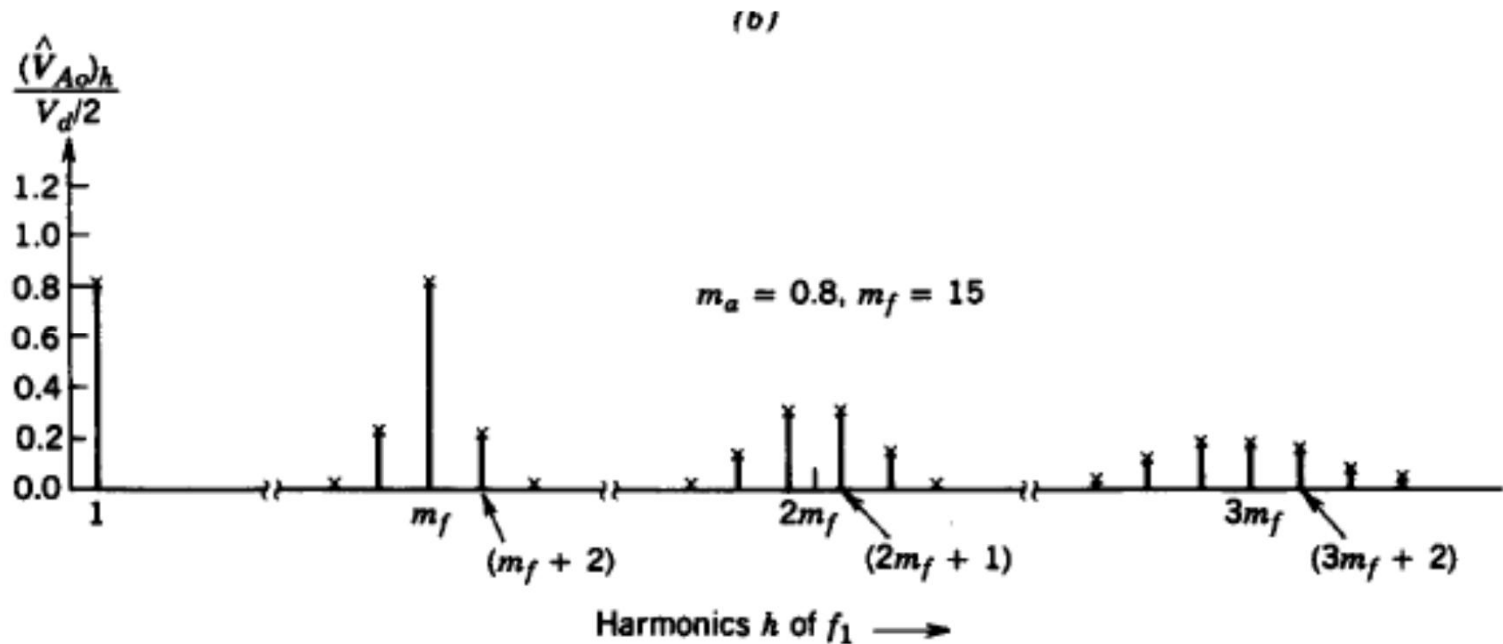

Harmonics due to m_a and $m_f > 9$

- For $m_f < 9$ is harmonics almost independent of m_f
- Choose m_f odd integer
 - Odd symmetry
 - Half-wave symmetry
 - Only odd harmonics
 - Even harmonics = 0
 - With $v_A = \hat{V}_A \sin \omega t$ all harmonics $\sin h\omega t$

Table 8-1 Generalized Harmonics of v_{Ao} for a Large m_f .

h \ m_a	0.2	0.4	0.6	0.8	1.0
<i>1</i>	0.2	0.4	0.6	0.8	1.0
<i>Fundamental</i>					
m_f	1.242	1.15	1.006	0.818	0.601
$m_f \pm 2$	0.016	0.061	0.131	0.220	0.318
$m_f \pm 4$					0.018
$2m_f \pm 1$	0.190	0.326	0.370	0.314	0.181
$2m_f \pm 3$		0.024	0.071	0.139	0.212
$2m_f \pm 5$				0.013	0.033
$3m_f$	0.335	0.123	0.083	0.171	0.113
$3m_f \pm 2$	0.044	0.139	0.203	0.176	0.062
$3m_f \pm 4$		0.012	0.047	0.104	0.157
$3m_f \pm 6$				0.016	0.044
$4m_f \pm 1$	0.163	0.157	0.008	0.105	0.068
$4m_f \pm 3$	0.012	0.070	0.132	0.115	0.009
$4m_f \pm 5$			0.034	0.084	0.119
$4m_f \pm 7$				0.017	0.050

Note: $(\hat{V}_{Ao})_{h/2} V_d [= (\hat{V}_{AN})_{h/2} V_d]$ is tabulated as a function of m_a .

Square-wave switching

- Each switch on a half cycle of the output frequency f_1

$$(\hat{V}_{Ao})_1 = \frac{4}{\pi} \frac{V_d}{2} = 1.273 \left(\frac{V_d}{2} \right)$$

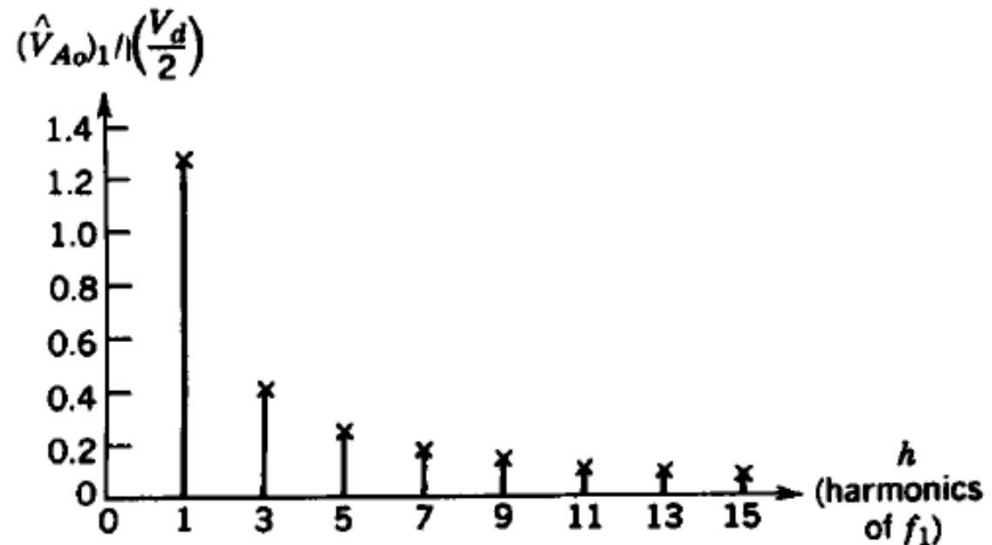
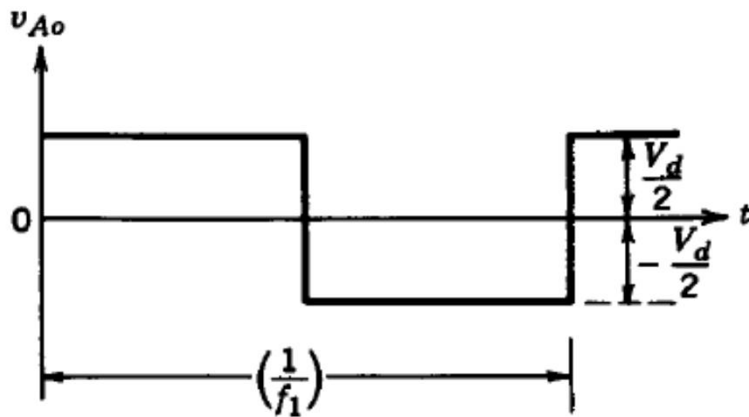

Over-modulation

- $m_a > 1$
- Increased harmonics with over-modulation

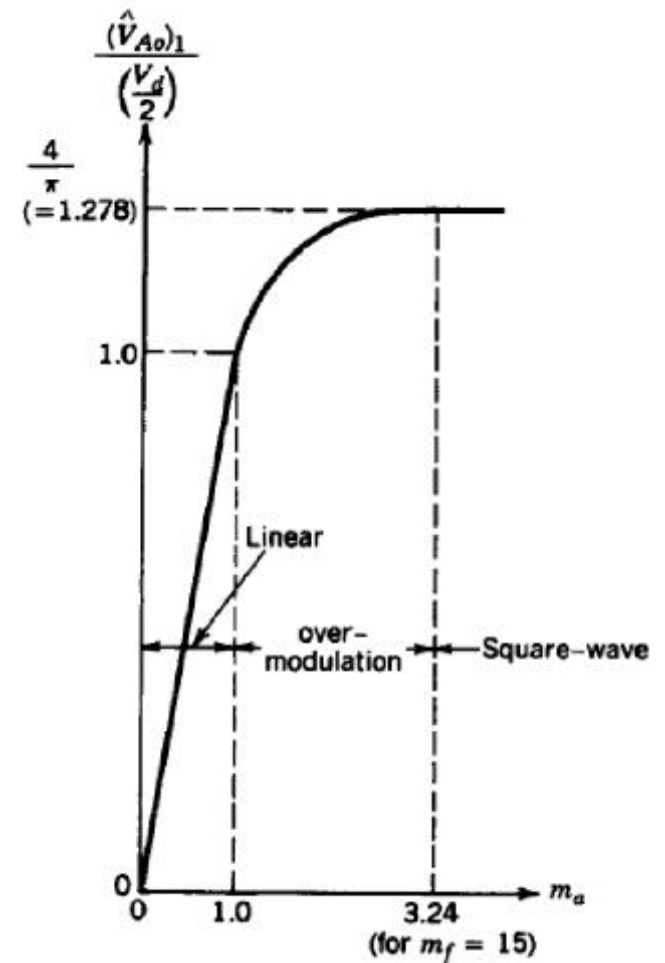
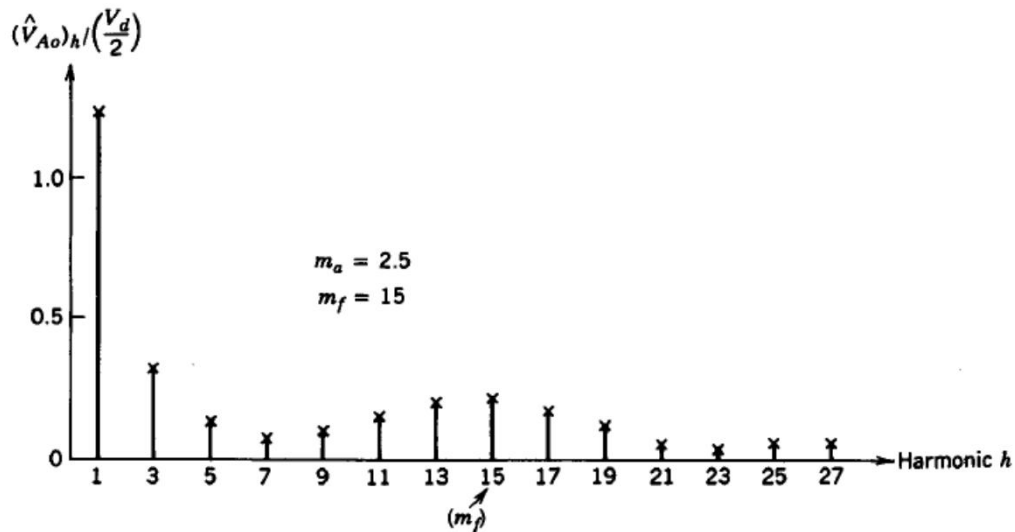

8-1

- In a single-phase full-bridge PWM inverter, the input dc voltage varies in a range of 295-325 V. Because of the low distortion required in the output v_o , $m_a < 1.0$.
 - a) What is the highest V_{o1} that can be obtained and stamped on its nameplate as its voltage rating?
 - b) Its nameplate volt-ampere rating is specified as 2000 VA, that is, $V_{o1,max} I_{o1,max} = 2000 \text{ VA}$, where i_o is assumed to be sinusoidal. Calculate the combined switch utilization ratio when the inverter is supplying its rated volt-amperes.

Ripple in single-phase inverter output

- Assume induction-motor load
- Counter electromotive force (emf) e_o

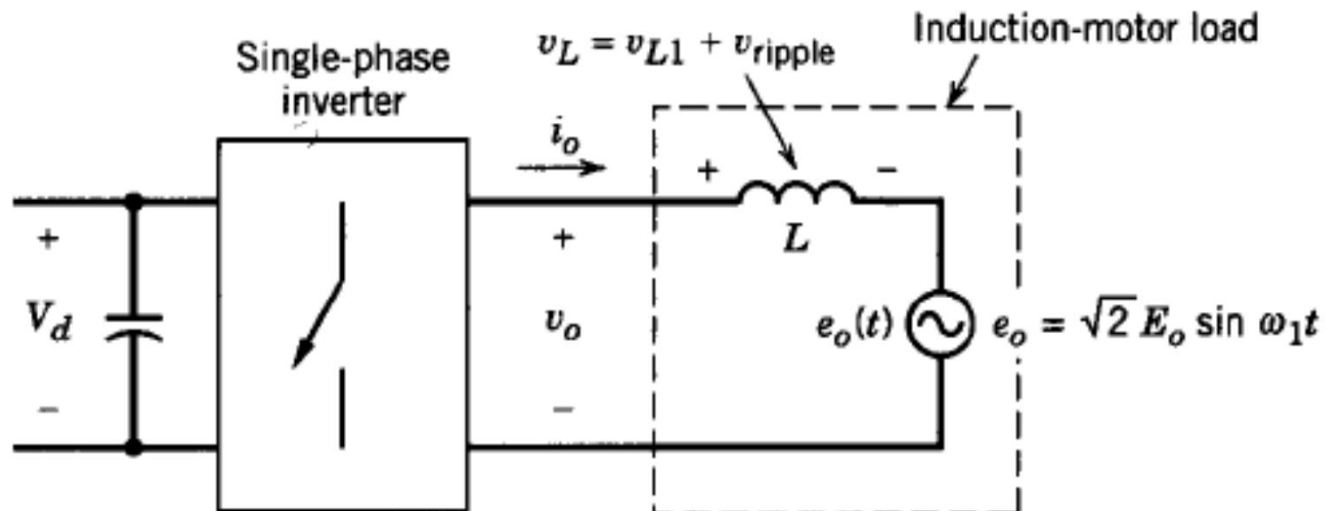

Ripple in single-phase inverter output, cont.

- Superposition gives two circuits
- Fundamental frequency components

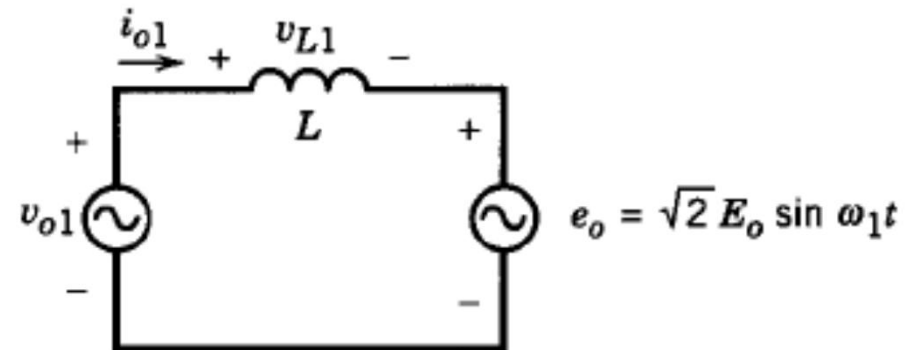
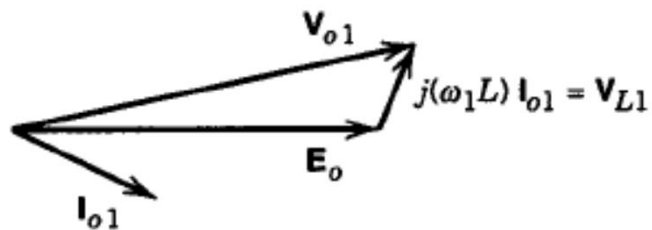

- All voltage ripple across L

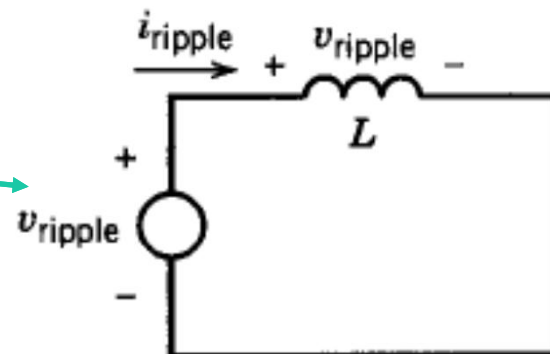

Ripple in single-phase inverter output, cont.

- Square wave vs PWM switching

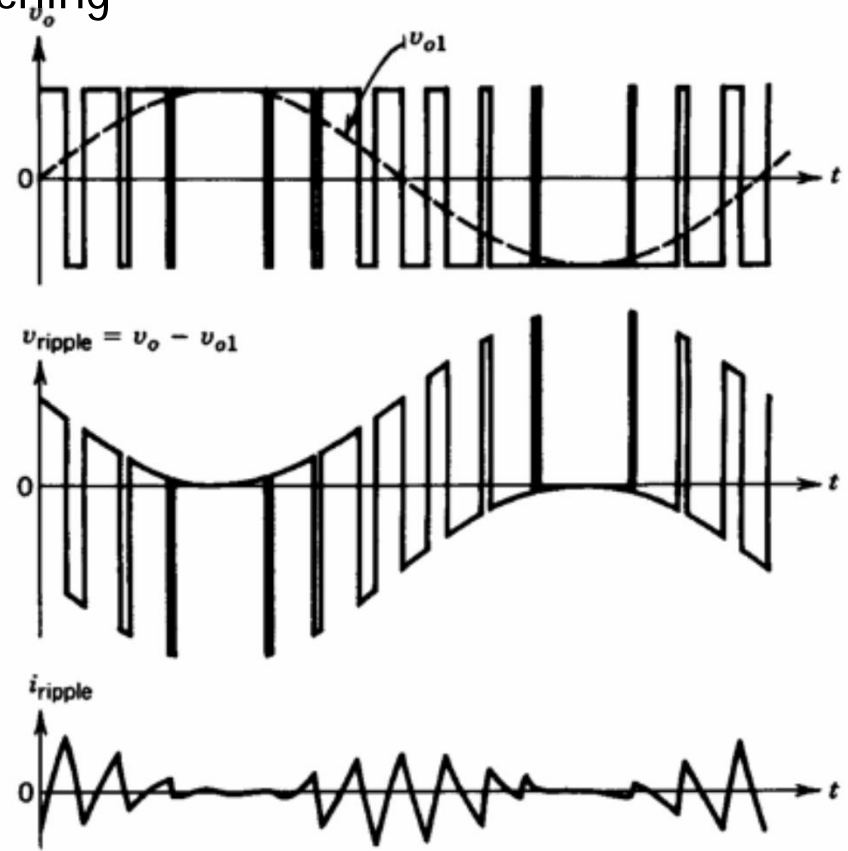
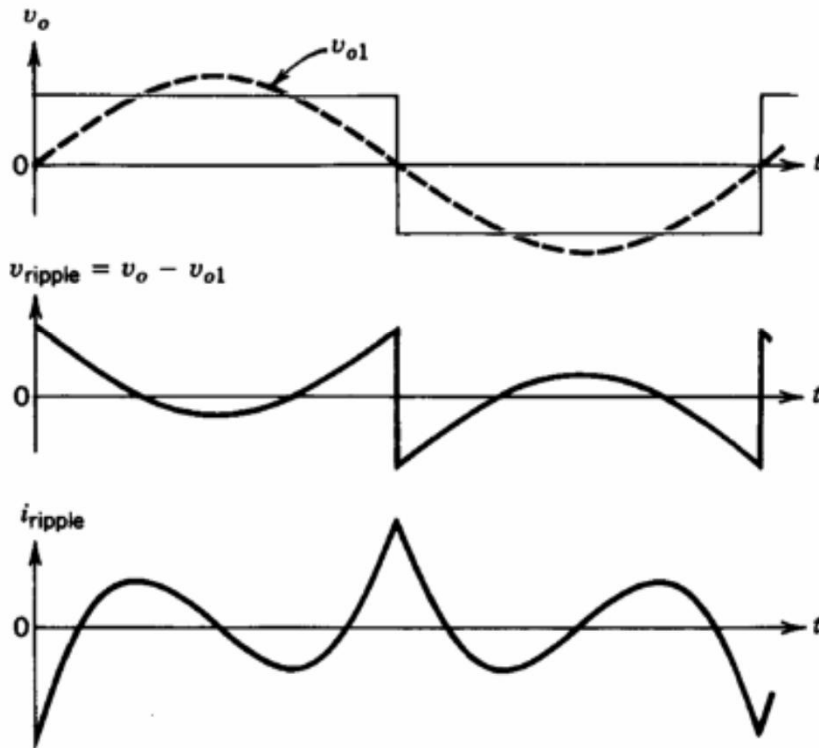

Switch utilization ratio

- The ratio between converter power rating and the combined rating of the switches

- $$\frac{V_{o1,max} I_{o1,max}}{q V_T I_T}$$

- $V_{o1,max}$ max fundamental output rms voltage
- $I_{o1,max}$ max fundamental output rms current
- q : number of switches
- V_T : Peak voltage rating a switching device
- I_T : Peak current rating of a switching device

Half-bridge converter example

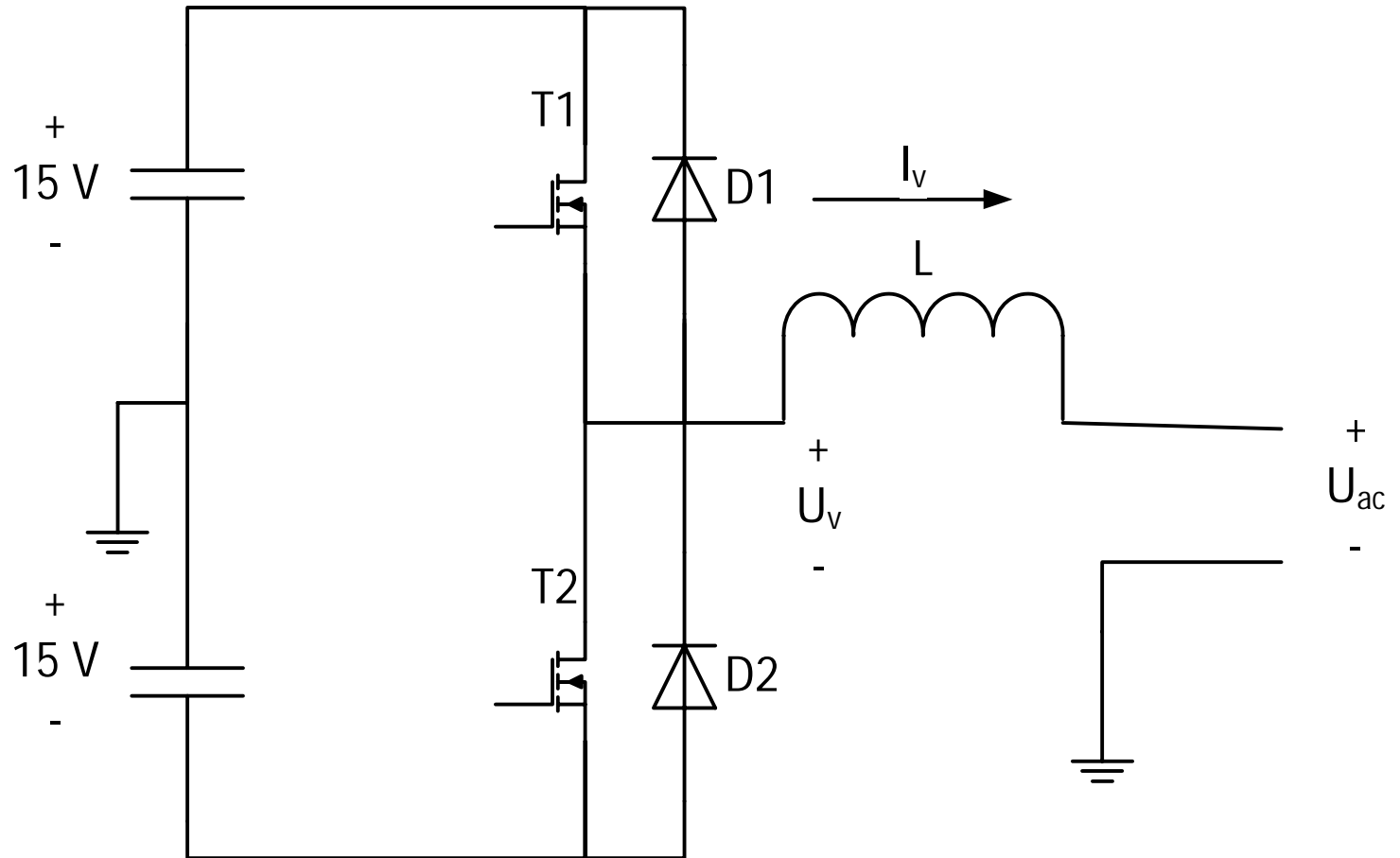

Output voltage & gate signals

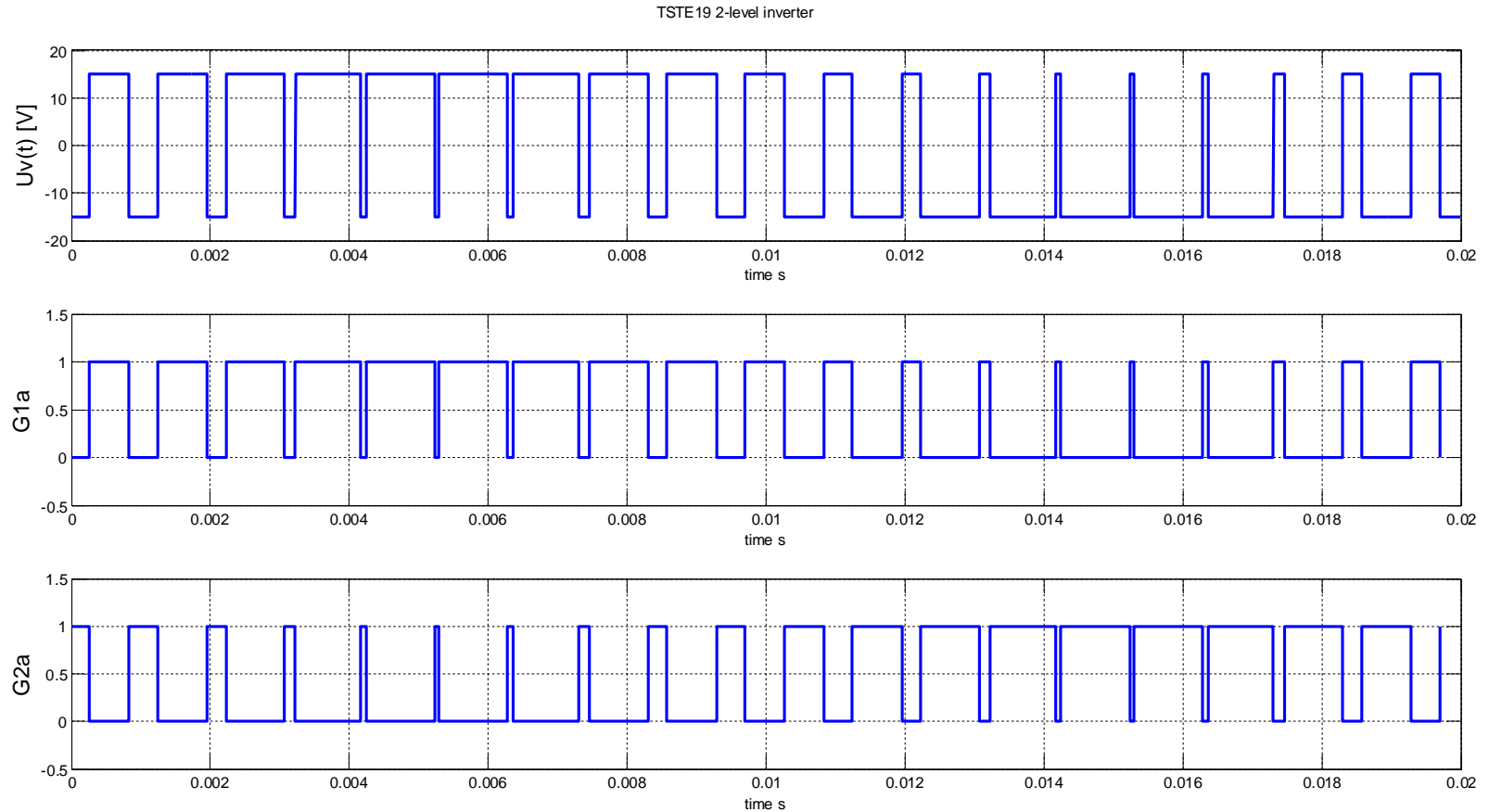

Voltage & current waveforms

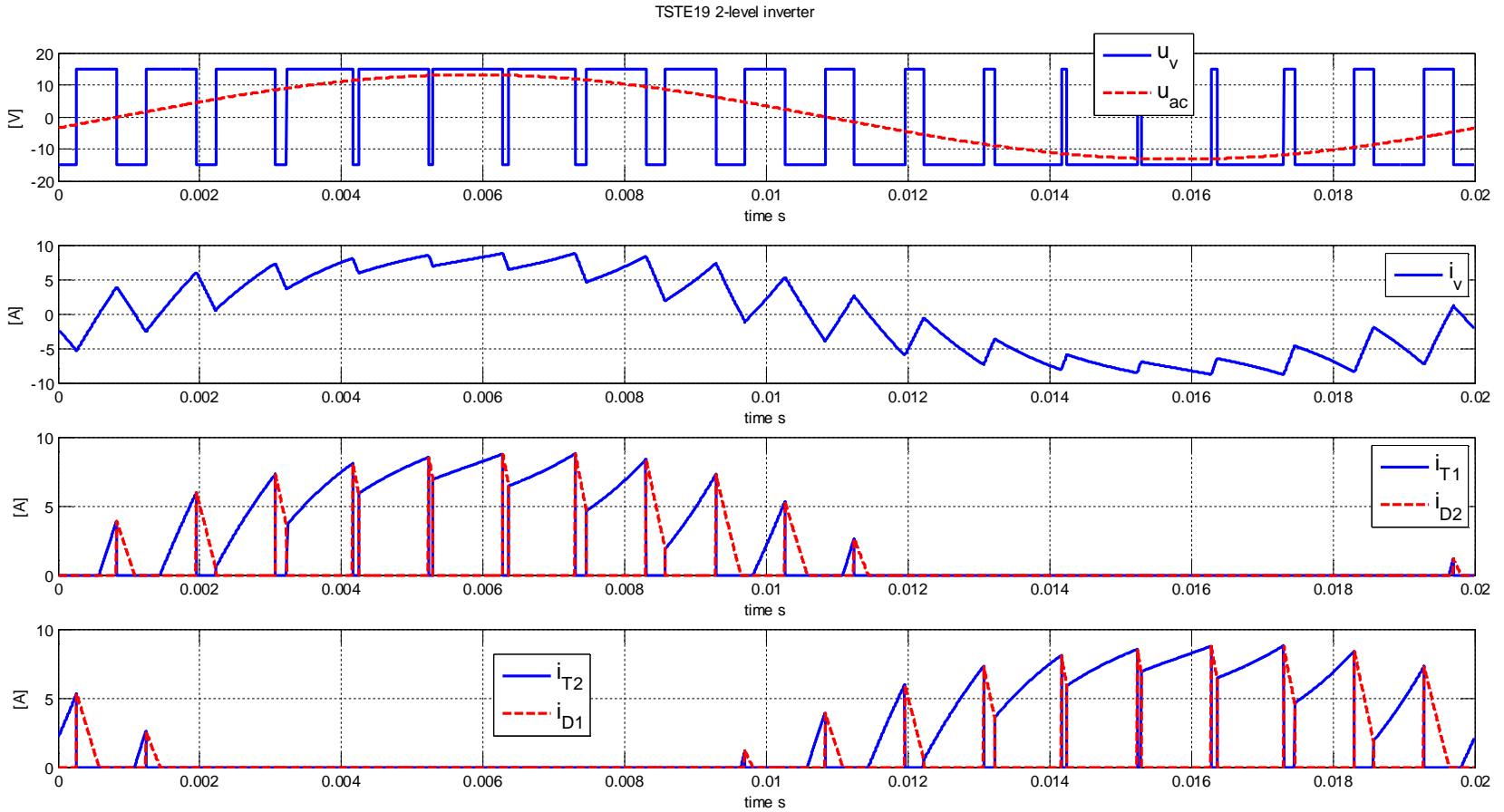

VSC Toolbox version 3.52. 23-Nov-2015 19:47:38

Zoom in of 1st ms

- $t < 0.27$ ms,
 - T2 on
 - $i_v < 0$
- $t = 0.27$ ms,
 - G2 off, G1 on
 - $i_v < 0$
 - T2 to D1 commutation
- $t = 0.57$ ms
 - $i_v > 0$
 - D1 to T1 conducting
- $t = 0.83$ ms
 - G1 off, G2 on
 - T1 to D2 commutation

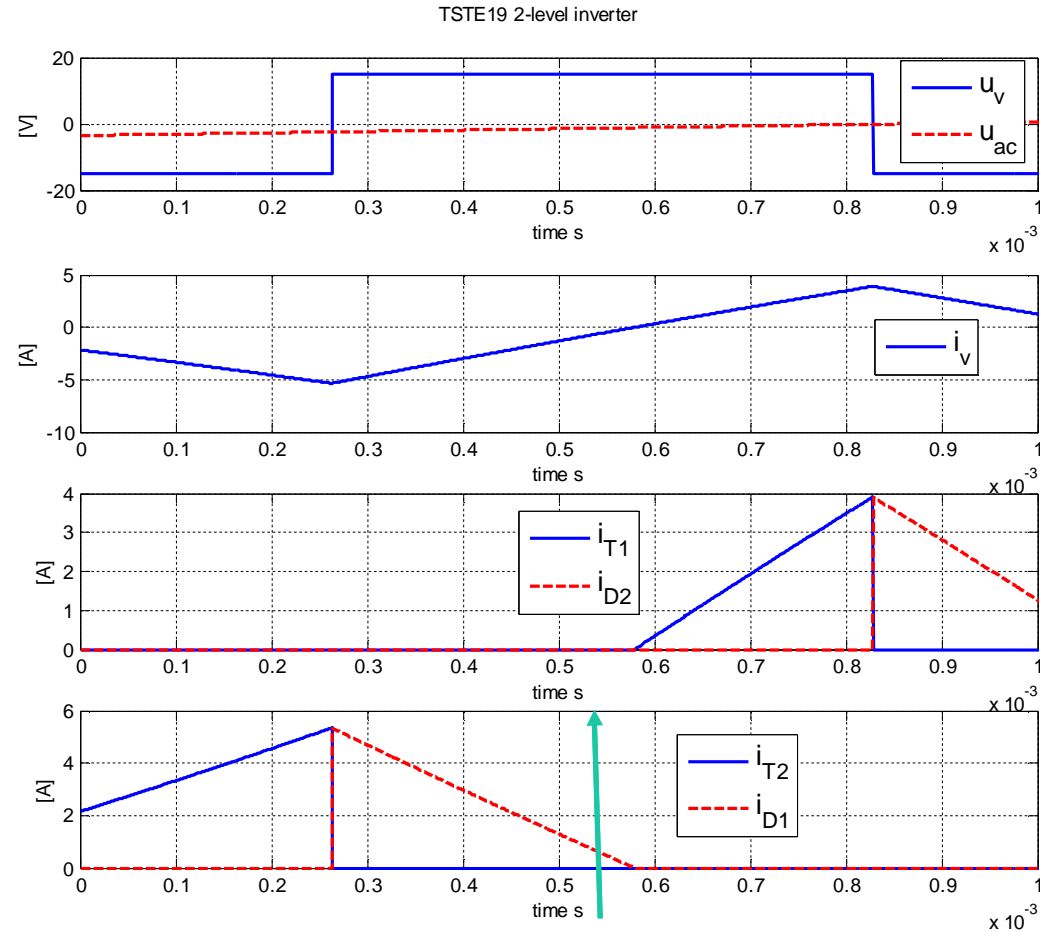

Half-bridge commutation

- Commutation between D1 and T2 or T1 and D2
- Commutation loop through dc-capacitor

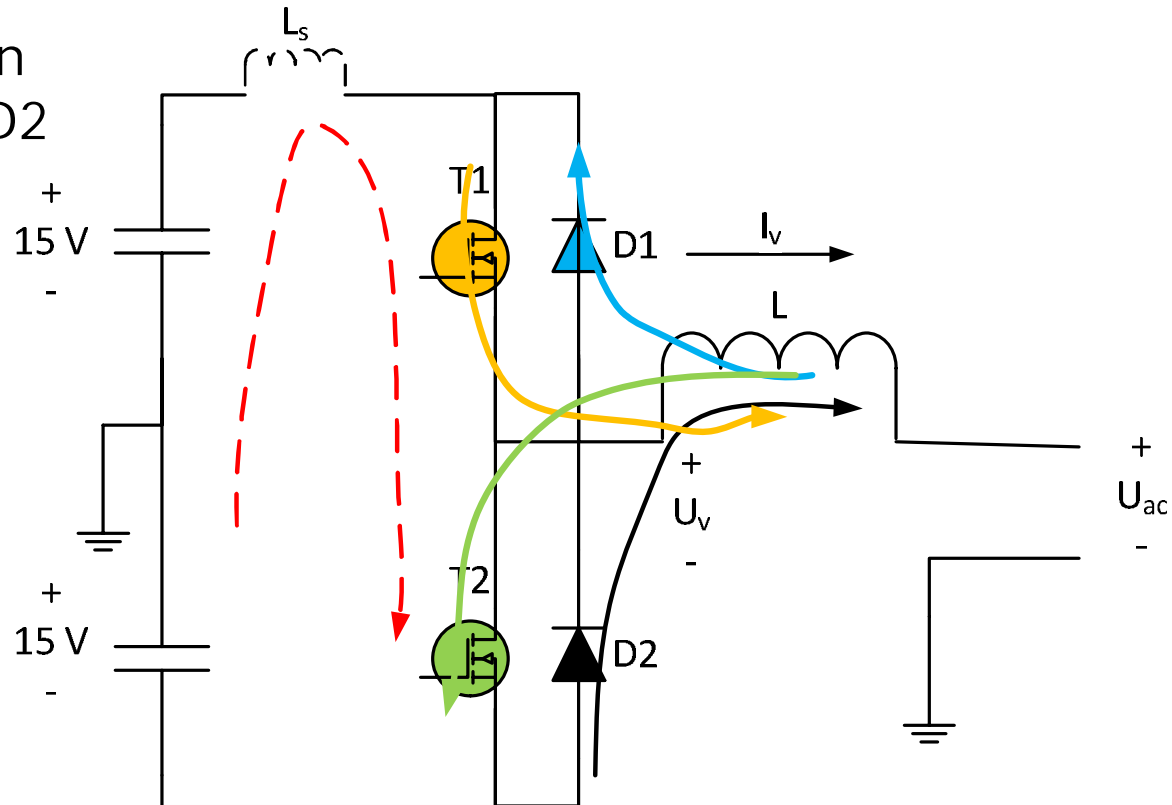

Exercise 7-100

In the half-bridge example with $U_d=30V$, answer the following:

1. What switching frequency is used?
2. Estimate the inductance value?
3. Estimate the peak fundamental current.
4. Modulation index m_a
5. Estimate the active and reactive power on the grid side. Consider the current i_v to be in phase with u_{ac} .
6. Estimate the phase angle of fundamental current with respect to the fundamental component of the switched valve side voltage, u_{v1} .
7. Calculate P and Q on the valve side.
8. Calculate the switch utilization ratio

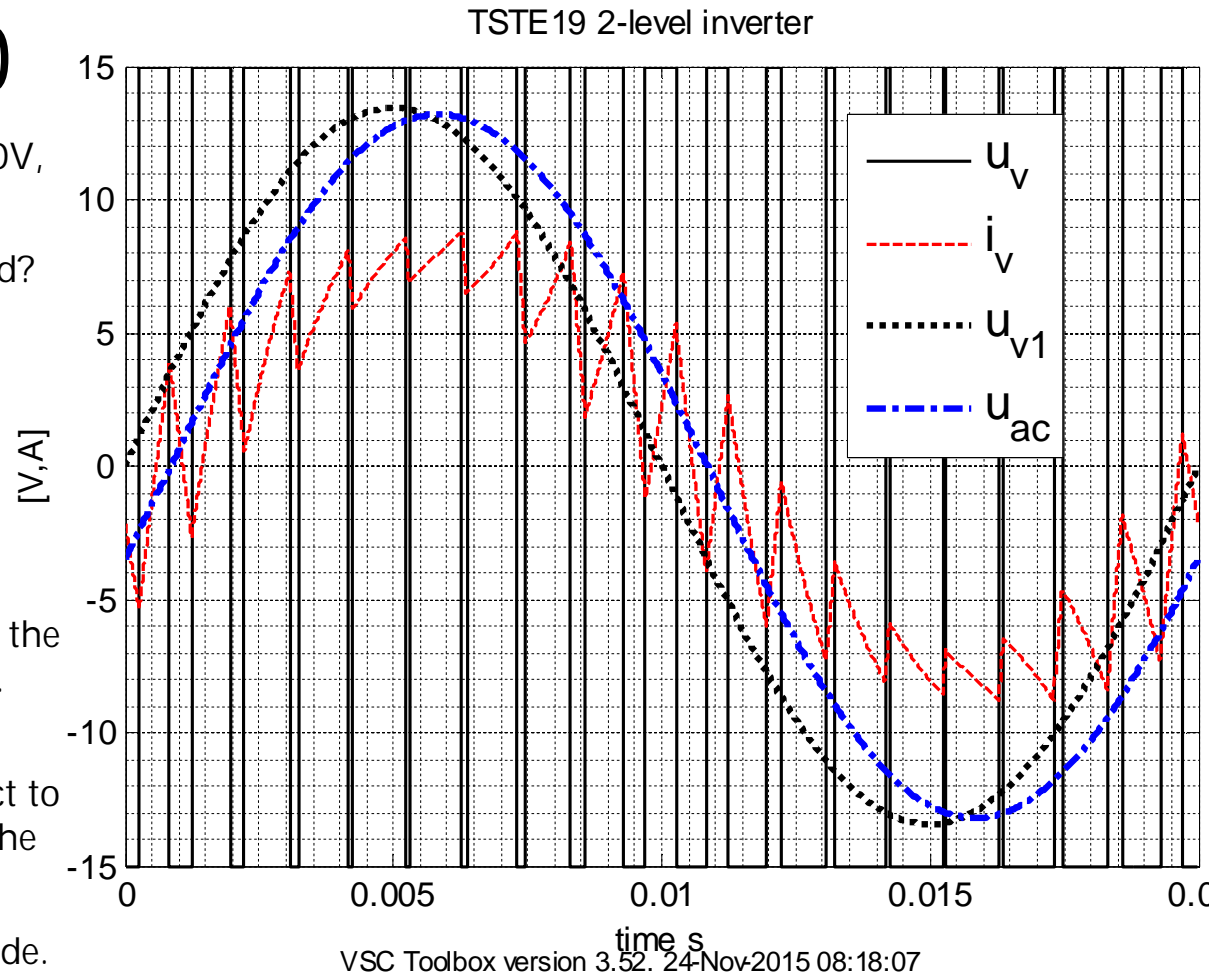

Unidirectional AC-AC converter

- Switch-mode inverter allow power reversal back to DC
- Motor sometimes behaving as a generator
- Use large capacitor to temporary store energy from ac motor
- May sometimes add resistor on DC to dissipate energy from motor braking

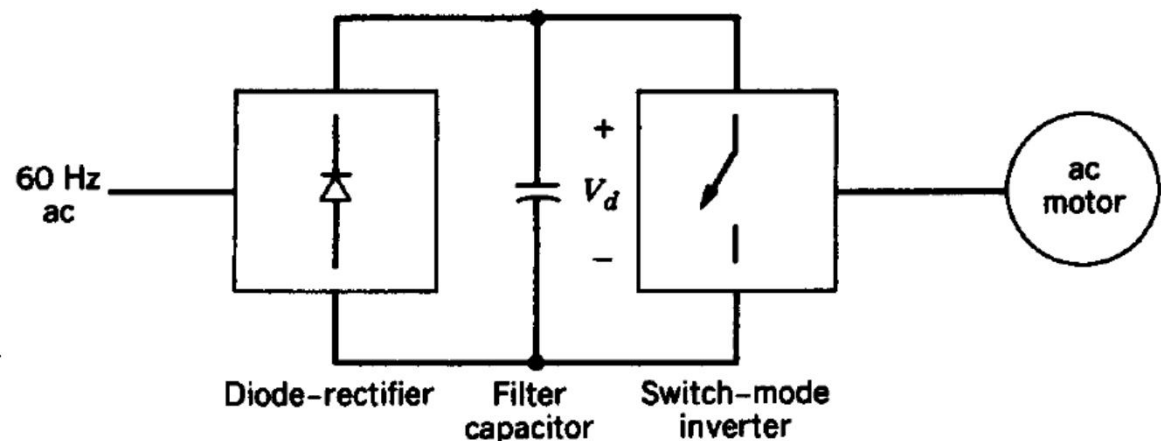

Bidirectional AC-AC converter

- When DC node can not accept all power from ac-motor
- E.g. train breaking, HVDC

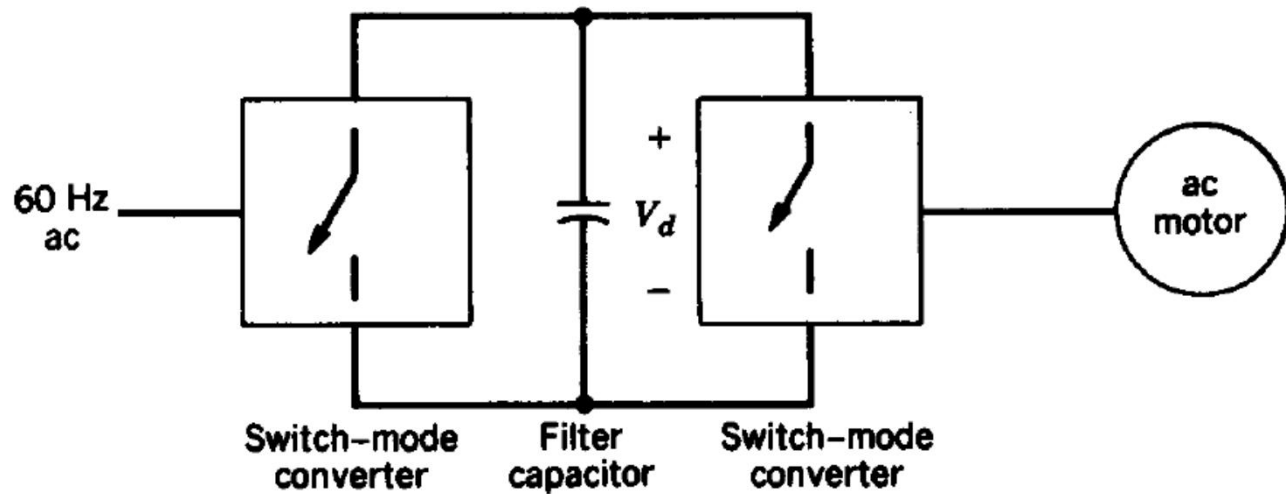

www.liu.se