

Tutorial 5: PLL, solutions

Problem 1 (9.2 Course book)

Determine the closed-loop transfer function, the damping factor ζ , and the natural frequency ω_n for the frequency-multiplying PLL shown below.

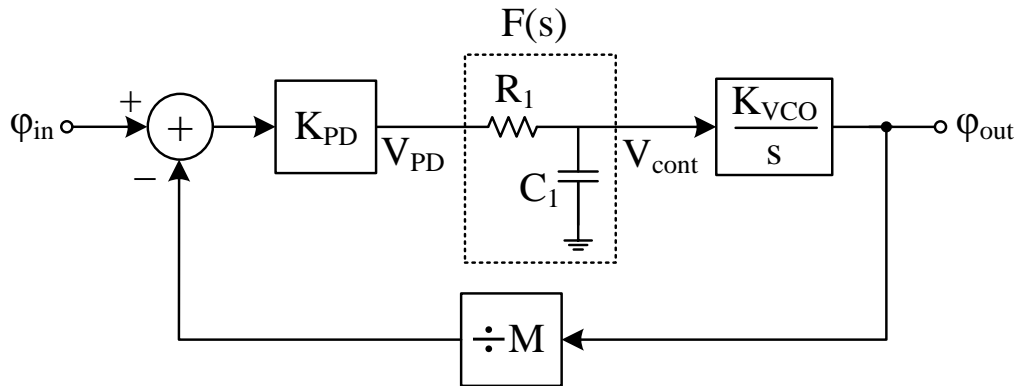

Solution:

$$F(s) = \frac{1}{\frac{1}{sC_1} + R_1} = \frac{1}{sR_1C_1 + 1}$$

The close loop Transfer Function:

$$\varphi_{out} = \frac{K_{VCO}K_{PD}}{s} \left(\varphi_{in} - \frac{\varphi_{out}}{M} \right) \left(\frac{1}{sR_1C_1 + 1} \right)$$

$$\frac{\varphi_{out}}{\varphi_{in}}(s) = \frac{K_{VCO}K_{PD}M}{s(sR_1C_1 + 1)M + K_{VCO}K_{PD}}$$

$$= \frac{K_{VCO}K_{PD}M}{s^2R_1C_1M + sM + K_{VCO}K_{PD}} = \frac{\frac{K_{VCO}K_{PD}}{R_1C_1}}{s^2 + s\frac{1}{R_1C_1} + \frac{K_{VCO}K_{PD}}{R_1C_1M}} = \frac{\frac{K_{VCO}K_{PD}}{R_1C_1}}{s^2 + 2\xi\omega_n s + \omega_n^2}$$

$$\omega_n = \sqrt{\frac{K_{VCO}K_{PD}\omega_{LPF}}{M}}$$

$$\xi = \frac{1}{2} \sqrt{\frac{\omega_{LPF}M}{K_{VCO}K_{PD}}}$$

Problem 2 (9.3 Course book)

Suppose the charge-pump PLL shown below is designed with $\zeta = 1$, and a loop bandwidth of $\omega_{in}/25$, and a tuning range of 10 %. Assume V_{cont} can vary from 0 to V_{DD} . Prove that the voltage drop across the loop filter resistor reaches roughly $1.6\pi V_{DD}$ if no second capacitor is used.

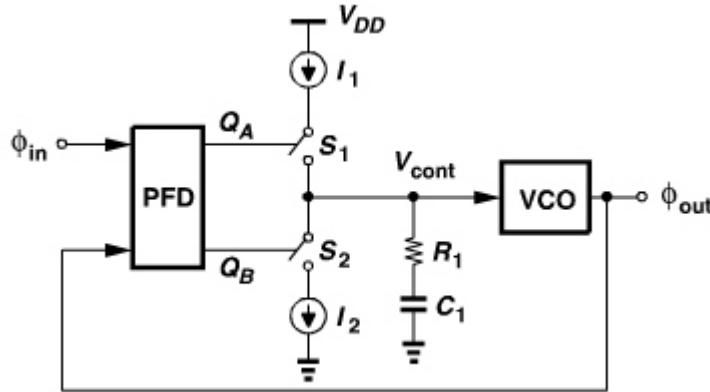
**Solution:**

From (9.20) and (9.21)

$$\omega_n = \sqrt{\frac{I_p K_{VCO}}{2\pi C_1}}$$

$$\xi = \frac{R_1}{2} \sqrt{\frac{I_p C_1 K_{VCO}}{2\pi}}$$

$$\xi = 1$$

From (9.28), the time constant of the loop is

$$\frac{1}{\xi \omega_n} = \frac{4\pi}{R_1 I_p K_{VCO}} = \frac{1}{\omega_n}$$

and the loop bandwidth is

$$\xi \omega_n = \frac{\omega_{in}}{25} = \frac{R_1 I_p K_{VCO}}{4\pi}. \quad (1)$$

From the tuning range assumption, we have

$$K_{VCO}(V_{cont,max} - V_{cont,min}) = 10\% * W_{in} \quad (2)$$

From (1) and (2):

$$K_{VCO} V_{DD} = 0.1 \omega_{in} = 25 \times 0.1 \frac{R_1 I_p K_{VCO}}{4\pi}$$

$$\Rightarrow R_1 I_p = \frac{4\pi}{25 \times 0.1} V_{DD} = 1.6\pi V_{DD}$$

Problem 3

Let us consider designing a common source power amplifier for a battery-operated portable device. We assume the basic specifications:

- 30 dBm output power is to be delivered to the antenna ($Z_L = 50 \Omega$), which corresponds to R_L in the figure.
- V_{DD} , the power supply voltage is 2.5 V. Depends on the battery and also is limited by the MOSFET breakdown voltage.

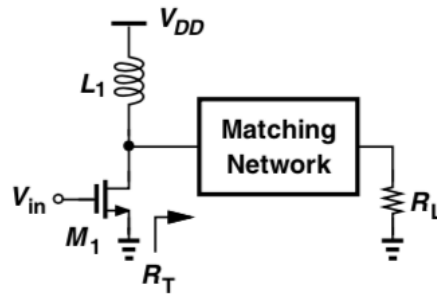

- a) How much output power in dBm can we achieve without modifying the amplifier?

$$P_L = \frac{V_p^2}{2R_L}, \text{ where } V_p \text{ is the peak voltage over the transistor } \approx V_{DD}.$$

Answer: $V_p = 2.5 \text{ V}$, $R_L = 50 \Omega \Rightarrow P_L = 2.5^2 / (2 * 50) = 0.063 \text{ W} = 18 \text{ dBm}$.

- b) How high supply do we need to reach 30 dBm output power?

$$\text{Answer: } P_L = 30 \text{ dBm} = 1 \text{ W. } V_p = \sqrt{2 * R_L * P_L} = \sqrt{2 * 50 * 1} = 10 \text{ V}$$

Achieving this takes several batteries in series. Also, 10 V supply will create high voltage over the transistor - 20 V, why? - which is much higher than standard CMOS transistor can handle. We need to test another way to reach 30 dBm output power.

- c) What load (R_L) can give 30 dBm output power?

Answer: $R_L = \frac{V_p^2}{2P_L} \Rightarrow R_L = 3.1 \Omega$. We need an impedance transformation network (sometimes called a matching network, but not strictly correct) at the amplifier's output.

- d) Let us design a transformation network that transforms the 50Ω load to the 3.1Ω load the power amplifier wants to see to deliver 30 dBm to the load. Which network(s) from the book, below, can do the job? Which one is best suited for our existing amplifier?

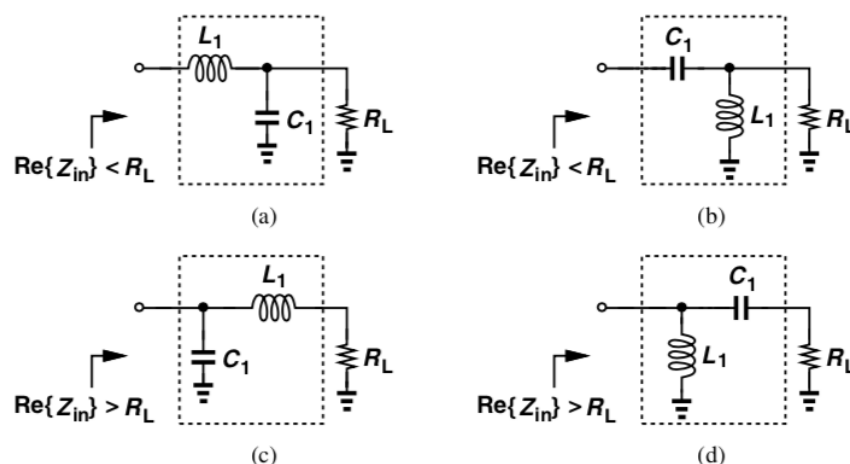

Figure 2.62 Four L sections used for matching.

Answer: (a) and (b) can be used, we want to transform 3.1Ω to 50Ω , i.e. $\text{Re}\{Z_{in}\} < R_L$. If C_1 in the existing circuit is not very large (BFC), it will also be part of the transformation network. Easier maybe to select (b) since we also need a series C (any value) to block DC current to flow from V_{DD} to R_L .

e) Maybe we can use the bondwire at the output of the amplifier (out from the chip to the package), then network (a) is how it will look like. (But we need to add a large C also as the DC block somewhere before the load.)

Calculate L_1 and C_1 values for 2 GHz using transformation (a) above. Let Q of the transformation network be very high. Can we use a bondwire?

Answer: See section 2.5.3 in the book:

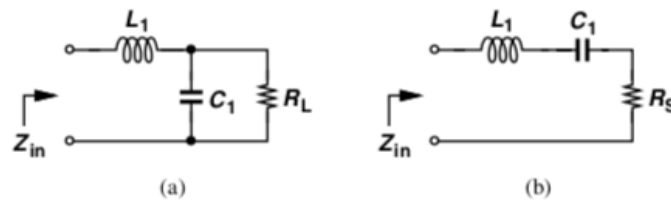

Figure 2.59 (a) Matching network, (b) equivalent circuit.

Writing Z_{in} from Fig. 2.59(a) and replacing s with $j\omega$, we have

$$Z_{in}(j\omega) = \frac{R_L(1 - L_1 C_1 \omega^2) + jL_1 \omega}{1 + jR_L C_1 \omega} \quad (2.176)$$

Thus,

$$\text{Re}\{Z_{in}\} = \frac{R_L}{1 + R_L^2 C_1^2 \omega^2} \quad (2.177)$$

$$= \frac{R_L}{1 + Q_p^2}, \quad (2.178)$$

Setting the imaginary part to 0:

$$L_1 = \frac{R_L^2 C_1}{1 + R_L^2 C_1^2 \omega^2} \quad (2.179)$$

$$= \frac{R_L^2 C_1}{1 + Q_p^2}. \quad (2.180)$$

If $Q_p^2 \gg 1$, then

$$\text{Re}\{Z_{in}\} \approx \frac{1}{R_L C_1^2 \omega^2} \quad (2.181)$$

$$L_1 = \frac{1}{C_1 \omega^2}. \quad (2.182)$$

So, C is given by (2.181) with $Z_{in} = 3.1 \Omega$, and L by (2.182), when the Q value is high.

$$C_1 = \frac{1}{\omega \sqrt{Z_{in} * R_L}} = 6.4 \text{ pF}. \quad L_1 = 0.99 \text{ nH}.$$

A 1 mm single bondwire is around 1 nH. Yes, the L of the matching network can be a bondwire!

Problem 4

Compute the maximum efficiency of the cascode PA shown here. Assume $M1$ and $M2$ nearly turn off but their drain currents can be approximated by sinusoids.

Answer:

The efficiency (drain efficiency) is

$$\eta = \frac{RF_{out}}{DC_{in}} = \frac{P_L}{V_{DD} * I_D}$$

The voltage in node X will swing between (almost) 0 and $2 * V_{DD}$.

$P_L = (2V_{DD}/2)^2 / (2 R_{in})$ where R_{in} is the apparent impedance in the matching network from node X.

$$I_D = V_{DD} / R_{in}$$

$$\Rightarrow \eta = \frac{V_{DD}^2 / 2R_{in}}{V_{DD}^2 / R_{in}} = 50 \%$$

The efficiency is the same for a cascode as for a single transistor.

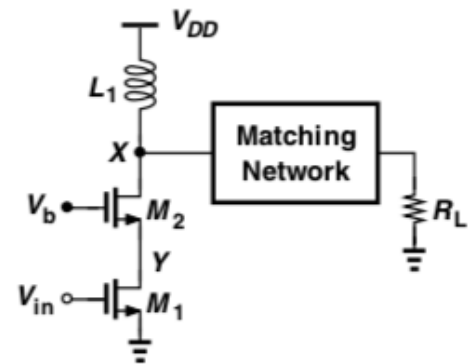

Homework

In the PLL shown below, derive the output-to-noise $\left(\frac{\phi_{out}}{V_{noise}}\right)$ transfer function.

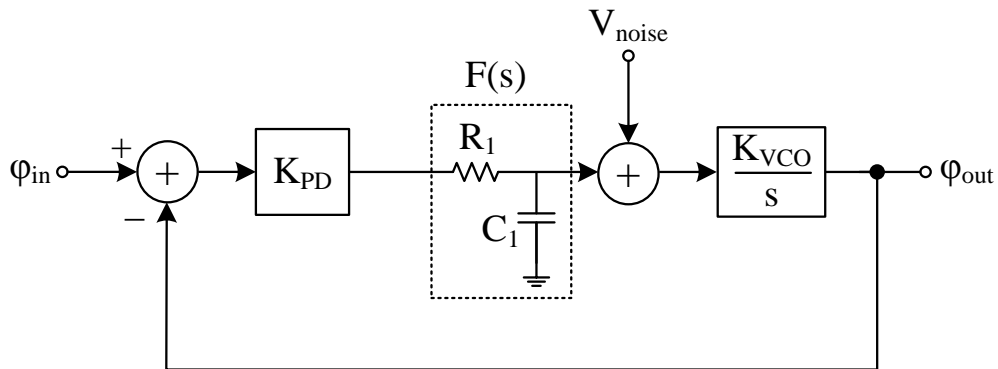

Answer:

$$F(s) = \frac{\frac{1}{sC_1}}{\frac{1}{sC_1} + R_1} = \frac{1}{sR_1C_1 + 1}$$

$$H(s) = \frac{\theta_{out}(s)}{V_{noise}(s)} = \frac{\frac{K_{VCO}}{s}}{1 + \frac{K_{VCO}K_{PD}F(s)}{s}}$$